

**kerrock**  
by KOLPA





# **Infinite power of imagination.**

DIE UNENDLICHE KRAFT DER FANTASIE.

LE POUVOIR INFINI DE L'IMAGINATION.

# Content

# Inhalt

# Contenu

6	KOLPA. KOLPA. KOLPA.
8	DURABILITY. NACHHALTIGKEIT. DURABILITÉ.
10	RECYCLING. RECYCLING. RECYCLAGE.
13	MARKET. MARKT. MARCHÉ.
15	KERROCK. KERROCK. KERROCK.
16	PROPERTIES. EIGENSCHAFTEN. PROPRIÉTÉS.
22	KERROCK PRODUCTION. KERROCK-PRODUKTION. PRODUCTION DE KERROCK.
<b>25</b>	<b>INTERIOR. INTERIEUR. INTÉRIEUR.</b>
26	HAVE LOOK INSIDE YOURSELF. BLICK INS INNERE. REGARDEZ À L'INTÉRIEUR.
29	BATHROOM. BADEZIMMER. SALLE DE BAINS.
32	KITCHEN. KÜCHE. CUISINE.
37	HOTEL. HOTEL. HÔTEL.
41	MEDICINE. MEDIZIN. MÉDECINE.
44	RETAIL. EINZELHANDEL. COMMERCE DE DETAIL.
49	BUSINESS PREMISES. GESCHÄFTSRÄUME. ESPACES PROFESSIONNELS.
53	PUBLIC INSTITUTIONS. ÖFFENTLICHE EINRICHTUNGEN. INSTITUTIONS PUBLIQUES.
57	WELLNESS. WELLNESS. BIEN-ÊTRE.
60	NAUTICS. NAUTIK. NAUTISME.
64	CARAVANNING. CARAVANING. CARAVANING.
<b>69</b>	<b>EXTERIOR. ÄUSSERES. EXTÉRIEUR.</b>
71	THE FIRST IMPRESSION MAKER. AUF DEN ERSTEN BLICK. CRÉATEUR DE LA PREMIÈRE IMPRESSION.

## **77** COLOURS. FARBEN. COULEURS.

- 78 UNI LIGHT.
- 80 UNI DARK.
- 82 GRANIT.
- 84 TERRAZZO.
- 86 NATUR.
- 90 MARBLE.
- 94 MIDNIGHT BLACK.
- 94 LUMINO.
- 94 LUMINACO.
- 95 METALIC.
- 95 KERROCK MF.
- 95 EASY SHAPING.

## **99** KERROCK PRODUCTS. KERROCK PRODUKTE. PRODUITS KERROCK.

- 101 WASHBASINS. WASCHBECKEN. VASQUES.
- 123 CUSTOM MADE VANITY TOPS AND WASHBASINS. MAßGEFERTIGTE WASCHTISCHE UND WASCHBECKEN. PLANS VASQUES ET LAVABOS SUR MESURE.
- 131 KITCHEN SINKS. KÜCHENSPÜLEN. ÉVIERS DE CUISINE.
- 136 — Kerrock inox. Kerrock inox. Kerrock inox.
- 138 SINKS FOR LABORATORIES. WASCHBECKEN FÜR LABORE. CUVES POUR LABORATOIRES.
- 141 BATHTUBS. BADEWANNEN. BAIGNOIRES.
- 145 BATHROOM EQUIPMENT. BADZUBEHÖR. ÉQUIPEMENT DE SALLE DE BAINS.
- 146 — Bathtubs. Badewannen. Baignoires.
- 157 — Shower trays. Duschwannen. Douches.
- 164 — Shower columns. Duschpaneele. Colonnes de douche.
- 169 DECORATIVE CLADDING. DEKORATIVE VERKLEIDUNGEN. REVÊTEMENT DÉCORATIF.
- 173 QUICKQUBE. QUICKQUBE. QUICKQUBE.
- 176 KERRWALL. KERRWALL. KERRWALL.
- 180 STANDARD SHEET DIMENSIONS. STANDARD-PLATTENABMESSUNGEN. DIMENSIONS STANDARDS DES PANNEAUX.
- 183 TECHNICAL DATA. TECHNISCHE DATEN. DONNÉES TECHNIQUES.
- 185 CERTIFICATES. ZERTIFIKATE. CERTIFICATS.

# Kolpa

Named after the river, in a place surrounded by wine-growing hills and birch forests, we have been proudly maintaining a leading position in the field of bathroom equipment in Europe for the fifth decade.

Development, innovation and trends are the cornerstones of our work. The uncompromising quality is the guarantee that gives our brands – the programs of Kolpasan premium bathroom equipment and Kerrock innovative composite material – the highest level of trust and reputation.

# Kolpa

Benannt nach dem Fluss, in einem Ort, der von Weinbergen und Birkenwäldern umgeben ist, behaupten wir seit fünf Jahrzehnten mit Stolz unsere Position als führende Marke für Badezimmerausstattung in Europa. Entwicklung, Innovation und Trends sind die Eckpfeiler unserer Arbeit. Kompromisslose Qualität ist die Garantie, die den Marken – der Premium-Badausstattungsreihe Kolpasan und dem innovativen Mineralwerkstoff Kerrock – das höchste Maß an Vertrauen und Ansehen gewährleistet.

# Kolpa

Nommée comme la rivière coulant, dans un endroit entouré de collines viticoles et de forêts de bouleaux, nous avons fièrement maintenu notre position de première marque de salle de bains en Europe au cours des cinq dernières décennies.

Le développement, l'innovation et les tendances sont les pierres angulaires de notre travail. La qualité sans compromis est la garantie qui confère aux marques Kolpasan (gamme d'équipements de salle de bains haut de gamme) et Kerrock (le matériau composite innovant), le plus haut niveau de confiance et de réputation.







REDUCING  
ENVIRONMENTAL IMPACTS.  
REDUZIERUNG DER  
UMWELTAUSWIRKUNGEN.  
RÉDUCTION DE L'IMPACT  
SUR L'ENVIRONNEMENT.

## Durability

"Signed with ISO 14001 environmental certification, we are constantly looking for new ways to use sustainable raw materials. We are aware that we are playing an important role in corporate social responsibility. For nature, the local environment and wider society. Committed to future generations and with innovative products and solutions, we want to create the biggest footprint of quality and the smallest footprint for the environment."

Director General Borut Šterbenc





# 95%

OF WASTE IS SUCCESSFULLY RECYCLED.  
DIE ABFÄLLE WERDEN ERFOLGREICH RECYCELT.  
DES DÉCHETS SONT RECYCLÉS AVEC SUCCÈS.

# 1/3

OF ENERGY IS OUR OWN GREEN ENERGY.  
ERZEUGUNG VON EIGENER GRÜNER ENERGIE. DE NOTRE ENERGIE EST NOTRE PROPRE ENERGIE VERTE.

# -65%

REDUCTION IN DRINKING WATER CONSUMPTION.  
WENIGER TRINKWASSERVERBRAUCH.  
DE CONSOMMATION EN EAU POTABLE.

## Nachhaltigkeit

„Mit dem Umweltzertifikat nach ISO 14001 sind wir ständig auf der Suche nach neuen Möglichkeiten, nachhaltige Rohstoffe zu verwenden. Wir sind uns der wichtigen Rolle im Bereich der sozialen Verantwortung bewusst. Für die Natur, die lokale Umwelt und die Gesellschaft insgesamt. Engagiert für zukünftige Generationen wollen wir mit innovativen Produkten und Lösungen den größten Fußabdruck für Qualität und den kleinsten Fußabdruck für die Umwelt schaffen.“

Generaldirektor Borut Šterbenc

## Durabilité

« Fort de la certification environnementale ISO 14001, nous sommes constamment à la recherche de nouveaux moyens d'utiliser des matières premières durables. Nous sommes conscients de notre rôle important dans le domaine de la responsabilité sociale des entreprises pour la Nature, l'environnement local et la société en général. Engagé pour les générations futures avec des produits et des solutions innovantes, nous voulons laisser la plus grande empreinte de qualité et la plus petite empreinte pour l'environnement »

Directeur général Borut Šterbenc

THE SHARE OF OWN-SOURCE HEATING.  
DER ANTEIL DER HEIZUNG AUS EIGENEN QUELLEN.  
PART DE NOTRE PROPRE SOURCE DE CHAUFFAGE.

# Recycling

Kerrock material residues can be reused as recyclable raw material for the production of new Kerrock sheets, as well as for other alternative uses and products.

In Kolpa, we reuse waste Kerrock sheet offcuts of certain colours. These Kerrock sheet scraps are ground, sieved into specific size fractions and used for the production of recyclable Kerrock sheets in certain colours. By recycling the material, we reduce Kerrock's carbon footprint without sacrificing its quality, durability and beauty.

# Recycling

Kerrock-Materialreste können als wiederverwertbarer Rohstoff für die Herstellung neuer Kerrock-Platten sowie für andere alternative Verwendungszwecke und Produkte wiederverwendet werden.

Bei Kolpa verwenden wir erneut die Reste von Kerrock-Platten in bestimmten Farben. Diese Kerrock-Restplatten werden gemahlen, in bestimmte Größenfraktionen gesiebt und für die Herstellung von recycelbaren Kerrock-Platten in bestimmten Farben verwendet. Indem wir das Material im Kreislauf führen, reduzieren wir den Kohlenstoff Fussabdruck von Kerrock ohne dabei die Qualität, Haltbarkeit und Optik vom Material zu verlieren.

# Recyclage

Les résidus de matériaux kerrock peuvent être réutilisés comme matière première recyclée pour la production de nouveaux panneaux kerrock, ainsi que pour la création de produits alternatifs.

Chez Kolpa, nous réutilisons les chutes de panneaux Kerrock de certaines couleurs. Ces déchets de panneaux Kerrock sont broyés, tamisés en particules de taille spécifique et utilisés pour la production de panneaux Kerrock recyclés. En recyclant le matériau, nous réduisons l'empreinte carbone de Kerrock sans sacrifier sa qualité, sa durabilité et sa beauté.

RECYCLED KERROCK  
SHEET  
RECYCELTE  
KERROCK-PLATTE  
PANNEAU KERROCK  
RECYCLÉ



KERROCK CUTTINGS  
RECYCELTE KERROCK  
STÜCKCHEN  
COUPES KERROCK



RECYCLED KERROCK CHIPPINGS  
RECYCELTE KERROCK STÜCKCHEN  
PARTICULES RECYCLÉS KERROCK

BRILLIANTE  
1080



SNOWFALL  
9257



ICEBERG  
N 1258



GRAYWACKE  
N 9259







MADE IN EUROPE  
HERGESTELLT IN EUROPA  
FABRIQUÉ EN EUROPE



QUALITY  
QUALITÄT  
QUALITÉ



CUSTOM DIMENSIONS  
ABMESSUNGEN NACH MAß  
DIMENSIONS  
PERSONNALISÉES



UNLIMITED DESIGN  
POSSIBILITIES  
UNBEGRENZTE  
DESIGNMÖGLICHKEITEN  
POSSIBILITÉS DE  
CONCEPTION ILLIMITÉES



CUSTOM COLOURS  
FARBEN NACH WUNSCH  
COULEURS SUR MESURE



LOWER CARBON FOOTPRINT  
GERINGERER  
KOHLENSTOFFDIOXID  
FUßABDRUCK  
FAIBLE EMPREINTE CARBONE

# Market

Supported by innovative material,  
we confidently look to the future  
and successfully conquer even the  
most demanding markets.

# Markt

Gestützt auf innovative Materialien  
blicken wir zuversichtlich in die  
Zukunft und erobern erfolgreich  
selbst die anspruchsvollsten Märkte.

# Marché

Grâce à des matériaux innovants,  
nous envisageons l'avenir avec  
confiance et conquérons avec  
succès les marchés les plus  
exigeants.

BAUXITE  
BAUXIT  
BAUXITE



ALUMINIUM  
HYDROXIDE  
ALUMINIUM-  
HYDROXID  
HYDROXYDE  
D'ALUMINIUM



100% ACRYLIC-  
BASED  
100 % AUF  
ACRYLBASIS  
100 % ACRYLIQUE



# Kerrock

A successful past has made it the material of the future. A perfect formulation of the Kerrock composite on the basis of aluminium hydroxide and acrylic constantly provides a non-porous and homogeneous bearer of aesthetics and functionality.

With the strength of stone and warmth of the sun, it makes a great impression on every interior and exterior, every time.

Get to know it. And then switch on your imagination.

# Kerrock

Eine erfolgreiche Vergangenheit hat es zum Material der Zukunft gemacht.

Die ausgeklügelte Formulierung des Kerrock-Mineralwerkstoff auf der Basis von Aluminiumhydroxid und Acryl liefert immer wieder einen porenfreien und homogenen Träger von Ästhetik und Funktionalität.

Mit der Kraft des Steins und der Wärme der Sonne hinterlässt es in jedem Innen- und Außenbereich einen großartigen Eindruck, und zwar jedes Mal.

Lernen sie das Material kennen. Und schalten Sie dann Ihre Fantasie ein.

# Kerrock

L'expérience du passé a fait le matériau de l'avenir. La formule sophistiquée du composite Kerrock, à base d'hydroxyde d'aluminium et d'acrylique, permet d'obtenir à chaque fois un support non poreux et homogène, à la fois esthétique et fonctionnel.

Avec la force de la pierre et la chaleur du soleil, il fait à chaque fois une grande impression à l'intérieur et à l'extérieur.

Apprenez à le connaître. Puis mettez votre imagination en marche.

# Properties Eigenschaften Propriétés



## EASY TO CLEAN

Despite the notorious stains, it remains immaculate. Whatever befalls him, it is easily cleaned with everyday kitchen cleaning agents.

## EINFACHE REINIGUNG

Trotz der berühmten Flecken, bleibt es unbefleckt. Was auch immer ihm widerfährt, kann es leicht mit normalen Küchenreinigungsmitteln gereinigt werden.

## FACILE À NETTOYER

A l'épreuve des tâches éventuelles, il reste immaculée. Quoi qu'il lui arrive, il se nettoie facilement avec des détergents habituels.

16



## 100% ACRYLIC

Quality is the key ingredient of Kerrock. Because it is polyester-free, odourless when cut, does not burn and absorbs less dirt.

## 100 % ACRYL

Kerrock zeichnet sich durch seine hohe Qualität aus. Da es polyesterfrei, geruchsneutral beim Schneiden ist, nicht brennt und weniger Schmutz absorbiert.

## 100 % ACRYLIQUE

La qualité est l'ingrédient clé de Kerrock. Car il ne contient pas de polyester, Kerrock est inodore à la coupe, ne brûle pas et absorbe moins de saletés.







#### NON-POROUSNESS

Always intact and immaculately beautiful surfaces with no room for intruders. A feature that makes it perfect for damp and wet conditions.

#### NICHT PORÖS

Immer unberührte und makellos schöne Oberflächen, in denen es keinen Platz für Eindringlinge gibt. Eine Eigenschaft, die sich perfekt bei feuchten und nassen Bedingungen anbietet.

#### NON-POREUX

Des surfaces toujours parfaites et d'une beauté immaculée où il n'y a pas de place pour les intrus. Une caractéristique qui le rend idéal pour les environnements humides et l'exposition à l'eau.



#### HEALTH AND ENVIRONMENT FRIENDLY

Since its inception, Kerrock has been extremely sustainable and at the same time safe in contact with food, which is also confirmed by the professional public with its range of certificates.

#### GESUNDHEITS- UND UMWELTFREUNDLICH

Kerrock ist seit seiner Einführung äußerst nachhaltig und auch im Kontakt mit Lebensmitteln sicher, was durch eine Reihe von Zertifizierungen der Fachwelt belegt wird.

#### RESPECTUEUX DE LA SANTÉ ET DE L'ENVIRONNEMENT

Kerrock est naturellement durable, il convient également au contact alimentaire. Kerrock est reconnu par la communauté Professionnelle.





#### INVISIBLE JOINTS

Aesthetics, without interruptions. Forms, limited only by your imagination.

#### FUGENLOS

Ästhetik, ohne Unterbrechungen. Formen, die nur durch Ihre Fantasie begrenzt werden können.

#### JOINTS INVISIBLES

L'esthétique, sans interruption. Des formes limitées que par votre imagination.



#### UV RESISTANCE

Glossy in colour and texture. Like the first day – everyday. Regardless to exposure to the sun's rays.

#### UV-BESTÄNDIGKEIT

Der Glanz und die Farbe bleibt genau so wie am ersten Tag, unabhängig von der Sonneneinstrahlung.

#### RÉSISTANCE AUX UV

Couleur et texture brillantes. Comme le premier jour – et les suivants même avec l'exposition aux rayons du soleil.





#### **THERMAL, HEAT RESISTANCE**

Outside. Inside. Hot. Cold. Wet. Dry. Tough and insensitive, wherever it may be.

#### **KLIMA-, HITZEBESTÄNDIGKEIT**

Draußen. Innen. Heiß. Kalt. Nass. Trocken. Hartnäckig und unsensibel, wo auch immer es eingesetzt wird.

#### **RÉSISTANCE THERMIQUE, AU CLIMAT**

À l'extérieur. À l'intérieur. Chaud. Froid. Humide. Sec. Dure et insensible, dans toutes les situations.



#### **SELF-EXTINGUISHING**

With its flame-retardant character, Kerrock will become your safe life companion.

#### **SELBSTLÖSCHEND**

Mit seinem schwer entflammaren Charakter wird Kerrock zu Ihrem sicheren Begleiter.

#### **AUTOEXTINGUIBLE**

Avec son caractère ignifuge, Kerrock deviendra votre compagnon de vie sûr.





#### ANTIBACTERIAL KERROCK+

Antibacterial Kerrock for surfaces without germs at every touch. King of pure premises in healthcare establishments and food preparation areas.

#### ANTIBAKTERIELL KERROCK+

Antibakterielles Kerrock für Oberflächen ohne Keime bei jeder Berührung. Der König der sauberen Räume in Gesundheitseinrichtungen und Lebensmittelzubereitungsbereichen.

#### KERROCK+ ANTIBACTÉRIEN

Kerrock antibactérien pour les surfaces sans microbes à chaque contact. Le roi des espaces propres dans les établissements de santé et les surfaces de préparation des aliments.



#### TRANSPARENT

In a special version, Kerrock can perform a play of light that seeps through its unwavering structure.

#### TRANSPARENT

In einer speziellen Version kann Kerrock ein Lichtspiel aufführen, das durch seine unerschütterliche Struktur durchdringt.

#### TRANSPARENT

Dans une version spéciale, Kerrock peut devenir le théâtre d'un jeu de lumière au coeur de sa structure inébranlable.

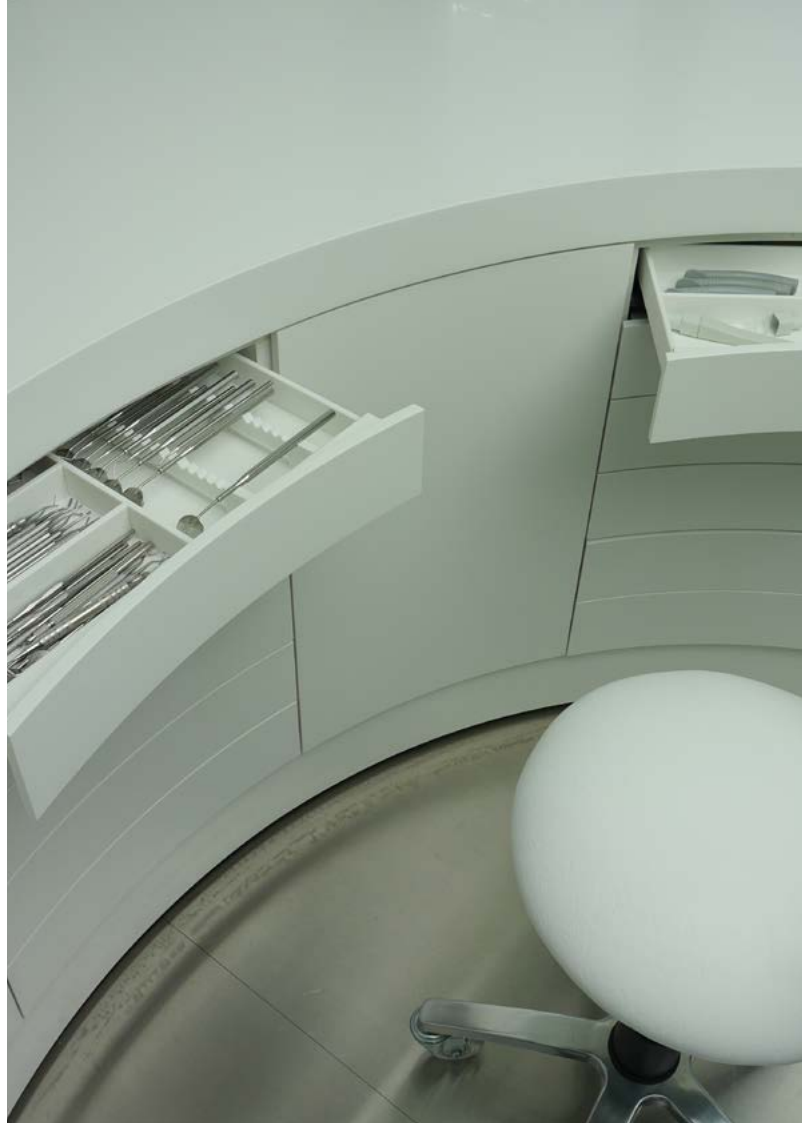



#### KERROCK EASY SHAPING

A cutting-edge innovation that makes it easy to thermoform smaller radii. Designers can express themselves with real freedom and create impressive formats in both interior and exterior.

#### KERROCK EASY SHAPING

Eine erstklassige Innovation, die das Thermoformen kleinerer Radien erleichtert. Designer können sich mit echter Freiheit ausdrücken und schaffen beeindruckende Formate im Bereich des Innen- und Außenbereichs.

#### KERROCK EASY SHAPING

Une innovation de pointe qui facilite le thermoformage de rayons très petits. Les concepteurs peuvent ainsi s'exprimer avec une réelle liberté et créer des formes impressionnantes à l'intérieur et l'extérieur.



#### KERROCK MF

Kerrock MF has become the first choice for nautical and the shipbuilding industry. Meets the highest standards under the MED Directive making it IMO certified.

#### KERROCK MF

Kerrock MF wurde zur ersten Wahl für die Schiffsbauindustrie. Erfüllt die höchsten Standards gemäß der MED-Richtlinie und ist daher IMO-zertifiziert.

#### KERROCK MF

Kerrock MF est devenu le premier choix dans l'industrie nautique et de la construction navale. Il répond aux normes les plus strictes de la directive MED, et possède ainsi le certificat IMO.



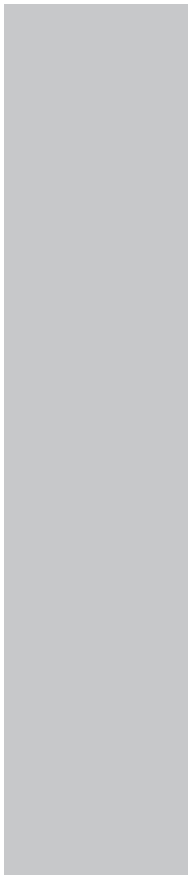

760 mm x 3600 mm

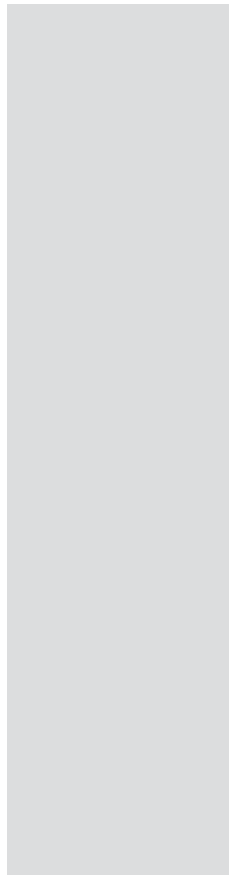

930 mm x 3600 mm

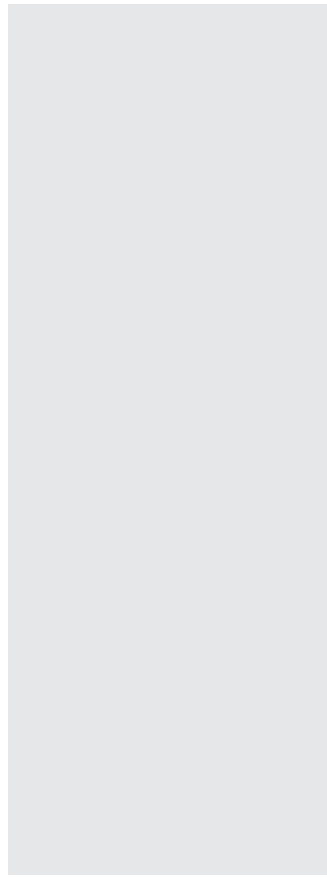

1350 mm x 3600 mm

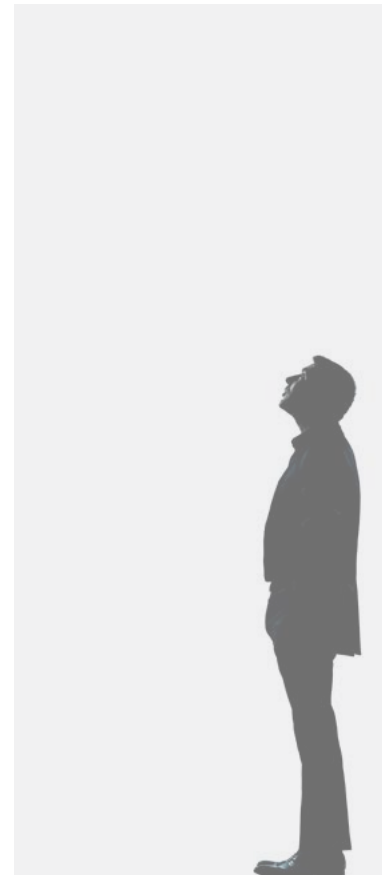

1520 mm x 3600 mm

# Kerrock production



Kerrock sheet widths: 500–1600mm  
Kerrock sheet thicknesses: 4–27mm



RAL scale or any other colours are developed in a very short time (two weeks); colour can be developed for smaller quantities of sheets, except Natur and Marble colors



Our own customised production of Kerrock bowls and sinks



In-house production and tinting of adhesives



Production of antibacterial Kerrock



Production of UV-resistant Kerrock for external surfaces

# Kerrock-Produktion



Kerrock-Plattenbreiten: 500–1600 mm  
Dicke der Kerrock-Platten: 4–27 mm



Wir entwickeln nicht nur Farbtöne nach der RAL - karte, sondern auch andere Farbtöne in sehr kurzer Zeit (innerhalb von zwei Wochen); die Farbe kann für kleinere Mengen von Platten entwickelt werden, außer der Natur und Marmorfarben.



Eigene Produktion von maßgefertigten Spülen und Waschbecken aus Kerrock



Eigene Herstellung und Abtönung von Klebstoffen



Herstellung von antibakteriellem Kerrock

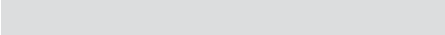

Herstellung von UV-beständigem Kerrock für Außenflächen

	4 mm
	6 mm
	9 mm
	12 mm
	18 mm

# Production de Kerrock



Largeur des panneaux Kerrock : 500–1600 mm  
épaisseur des panneaux Kerrock : 4–27 mm



Nous développons les couleurs RAL ou autres couleurs en très peu de temps (deux semaines);  
Nous développons également pour de petites quantités de plaques, sauf Nature et couleurs de marbre.



Production de vasques et de lavabos Kerrock sur mesure



Production et mise en teinte d'adhésifs



Production de Kerrock antibactérien



Production de Kerrock résistant aux UV pour les surfaces extérieures





**We are paving  
new channels  
for the flow of  
opportunities.**

WIR BEREITEN NEUE KANÄLE FÜR DEN  
FLUSS DER MÖGLICHKEITEN.

NOUS CRÉONS DE NOUVEAUX SENTIERS  
POUR LES FLUX D'OPPORTUNITÉS.





**Interior**  
**Intérieur**  
**Intérieur**

# Have a look inside yourself

Give in to your emotions and give them shape. Embrace a bold aesthetic. Enjoy the freshness of nature, the security of well-thought-out functionality and call it home.

# Blick ins Innere

Geben Sie Ihren Gefühlen nach und zeichnen Sie eine Form um sie herum. Setzen Sie auf eine kühne Ästhetik. Genießen Sie die Frische der Natur, die Sicherheit einer durchdachten Funktionalität und nennen Sie es Zuhause.

# Trouvez l'inspiration

Laissez-vous aller à vos émotions et dessinez leur forme. Vivez dans un endroit d'une esthétique audacieuse. Profitez de la fraîcheur de la nature, de la sécurité du bien pensé et faites comme chez vous.









# Bathroom

Morning motivation or an evening of washing the stress away. A bathroom that has long since gone beyond traditional body care and offers your being a daily dose of zen.

*APPLICATION: Vanity tops/shelves/racks/shelving/wall cladding*

# Badezimmer

Morgendliche Motivation oder abendliches Entspannen. Ein Bad, das längst über die traditionelle Körperpflege hinausgeht und Ihrem Geist ein tägliches Zen bietet.

*EINSATZ: Waschtischunterschranke mit Becken/ Ablagen/Regale/Bodenbelägen/Wandverkleidungen – eine Alternative zu Keramikfliesen*

29

# Salle de bains

Motivation du matin ou lavage de stress du soir. Une salle de bains qui dépasse depuis longtemps les simples soins corporels traditionnels en offrant à votre être un zen quotidien.

*UTILISATION : Plans de toilette avec vasques/étagères/ supports/rayons/revêtements muraux – une alternative aux plaques de céramique*

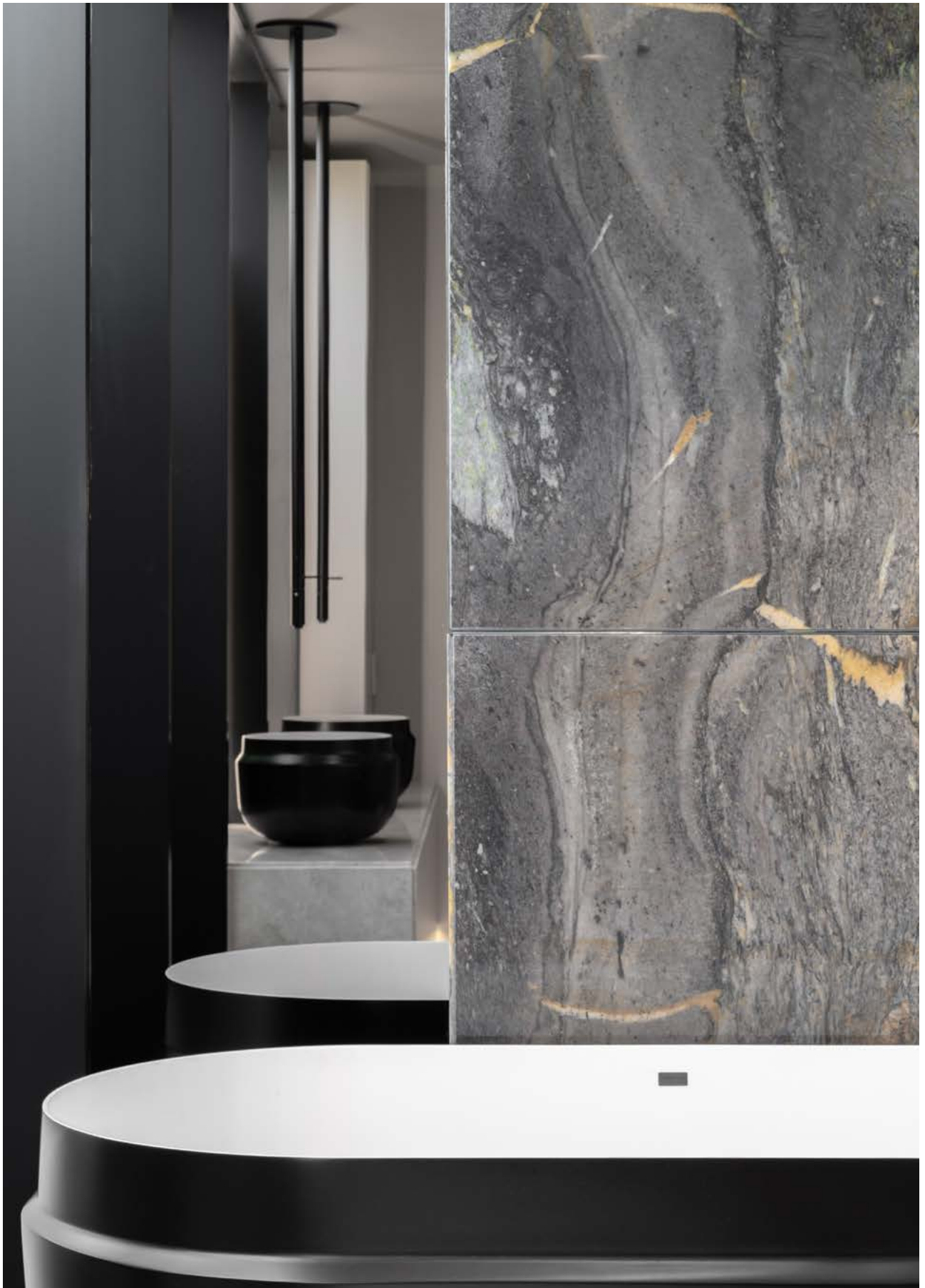

**Project: Antinorma**  
Romania  
Architecture: Phenomena laboratory  
Photography: Vlad Patru



# Kitchen

Kerrock kitchens. It is a matter of good taste and sound judgement. Sound to the touch and mechanically resistant to all culinary adventures.

*APPLICATION: Countertops with kitchen sink/wall cladding/tables/kitchen islands/shelves/racks*

# Küche

Kerrock-Küchen. Es ist eine Frage des guten Geschmacks und des gesunden Urteilsvermögens. Angenehme Haptik und mechanisch widerstandsfähig bei allen kulinarischen Abenteuern.

*EINSATZ: Arbeitsplatten mit Spüle/Wandverkleidungen/ Tische/Kücheninseln/Regale/Ablagen*

# Cuisine

Cuisines Kerrock. C'est juste une question de bon goût et de bon sens. Sain au toucher et mécaniquement résistant à toutes les aventures culinaires.

*UTILISATION : Plans de travail avec évier/crédiences/ tables/îlots de cuisine/étagères/supports*







**Project: Antinorma**

Romania

Architecture: Phenomena laboratory

Photography: Vlad Patru

**Project: Antinorma**

Romania

Architecture: Phenomena laboratory,

Photography: Vlad Patru

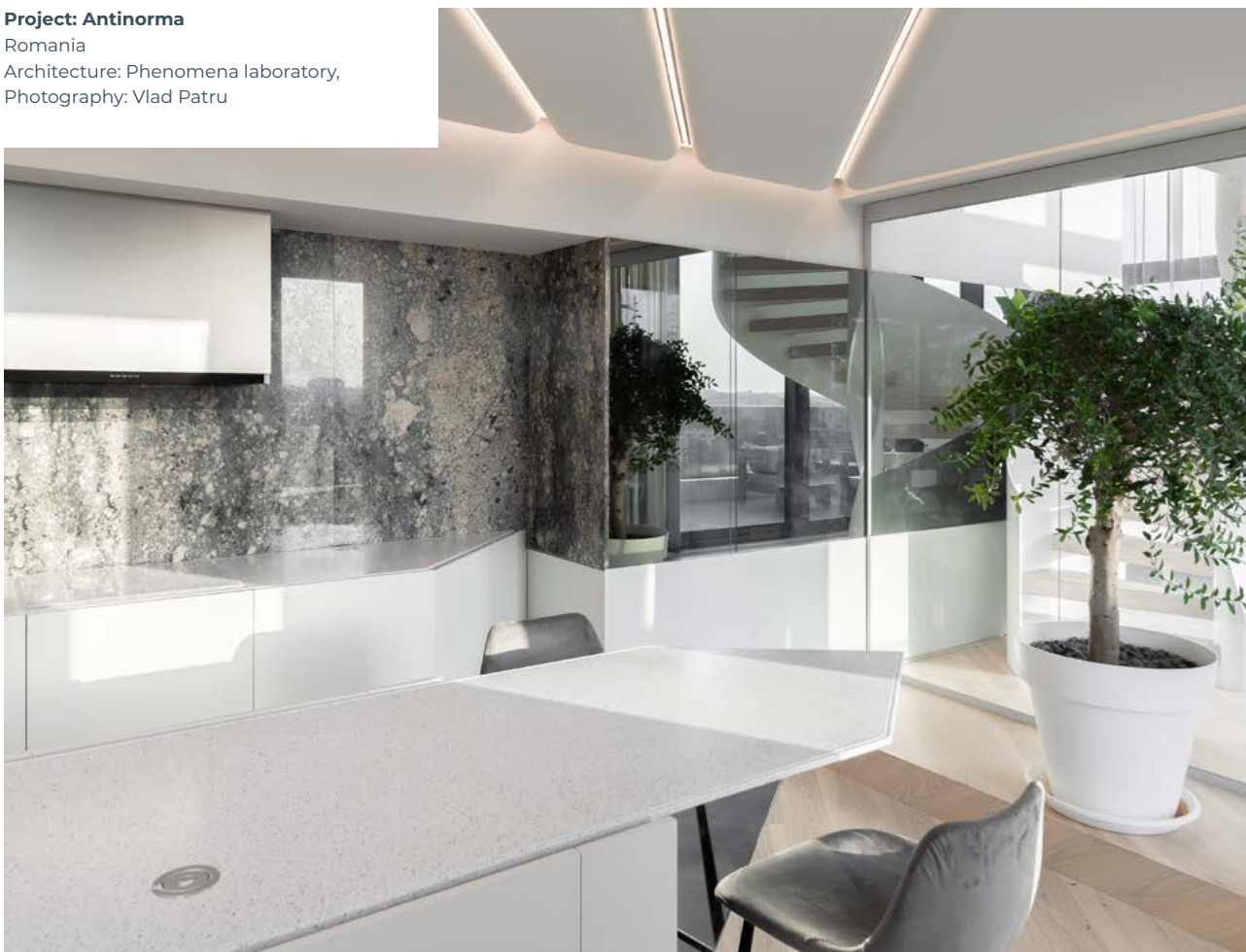

34

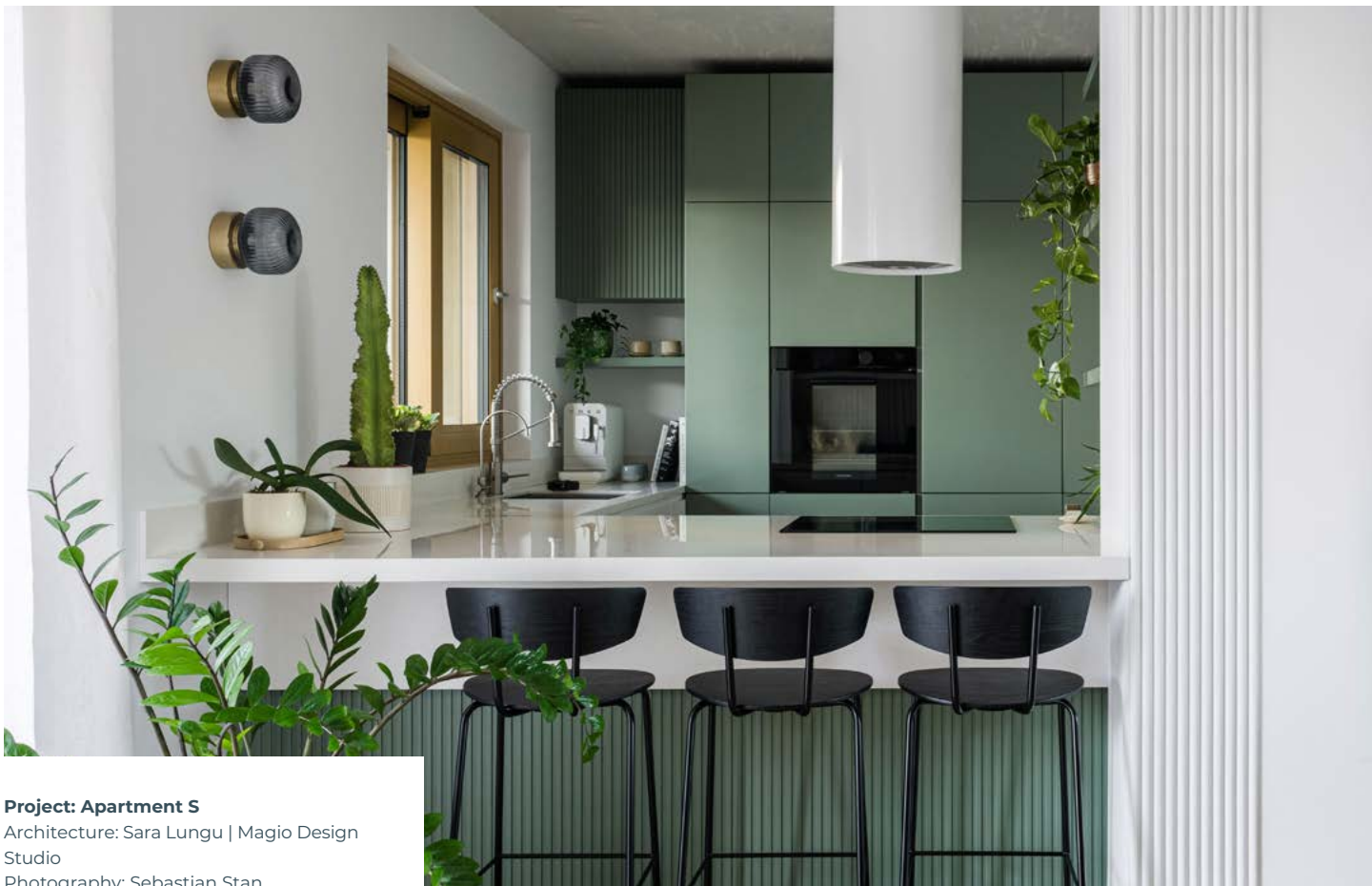

**Project: Apartment S**

Architecture: Sara Lungu | Magio Design Studio

Photography: Sebastian Stan

**Project: More is more**

Romania  
Architecture: Phenomena laboratory,  
Photography: Vlad Patru

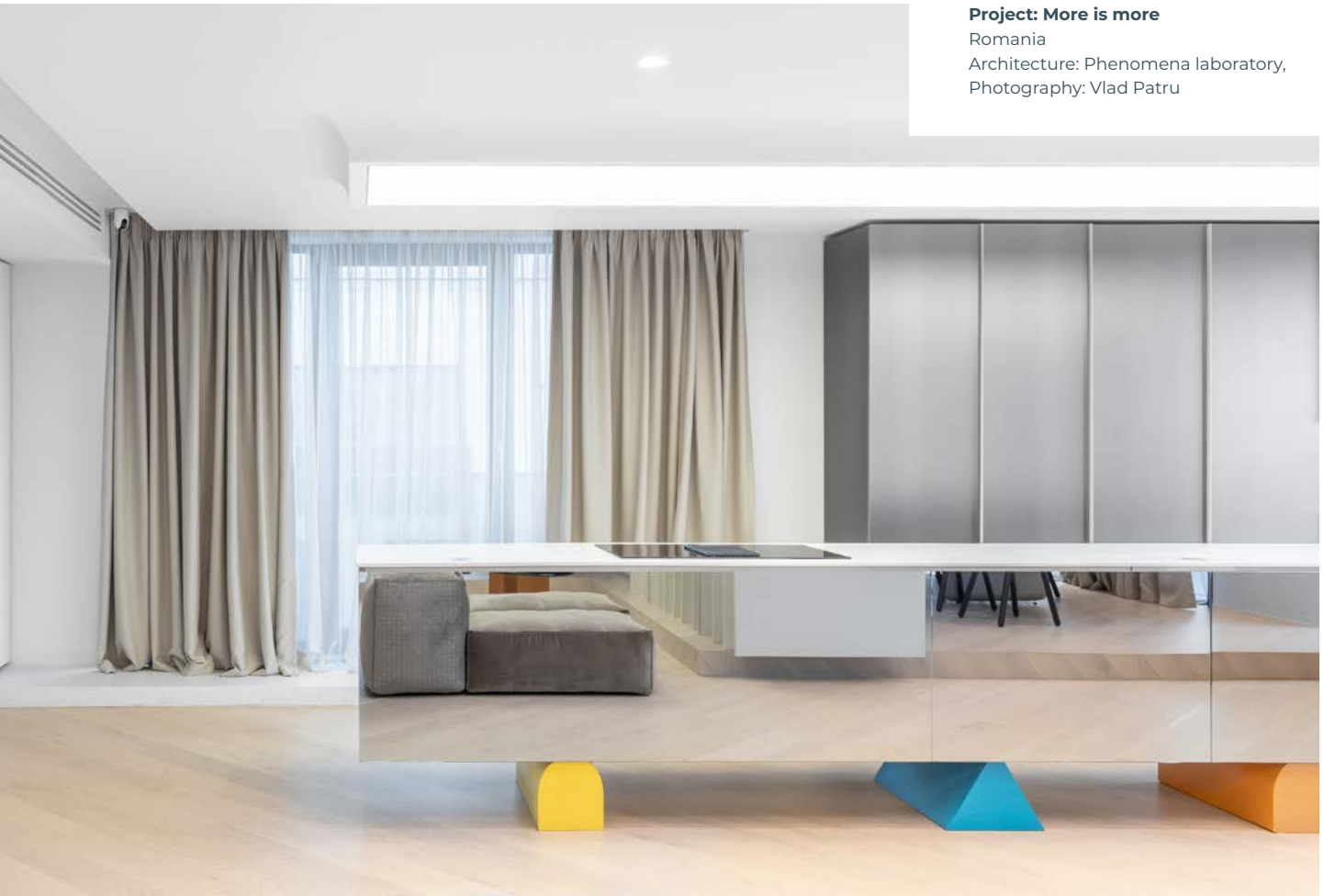

35

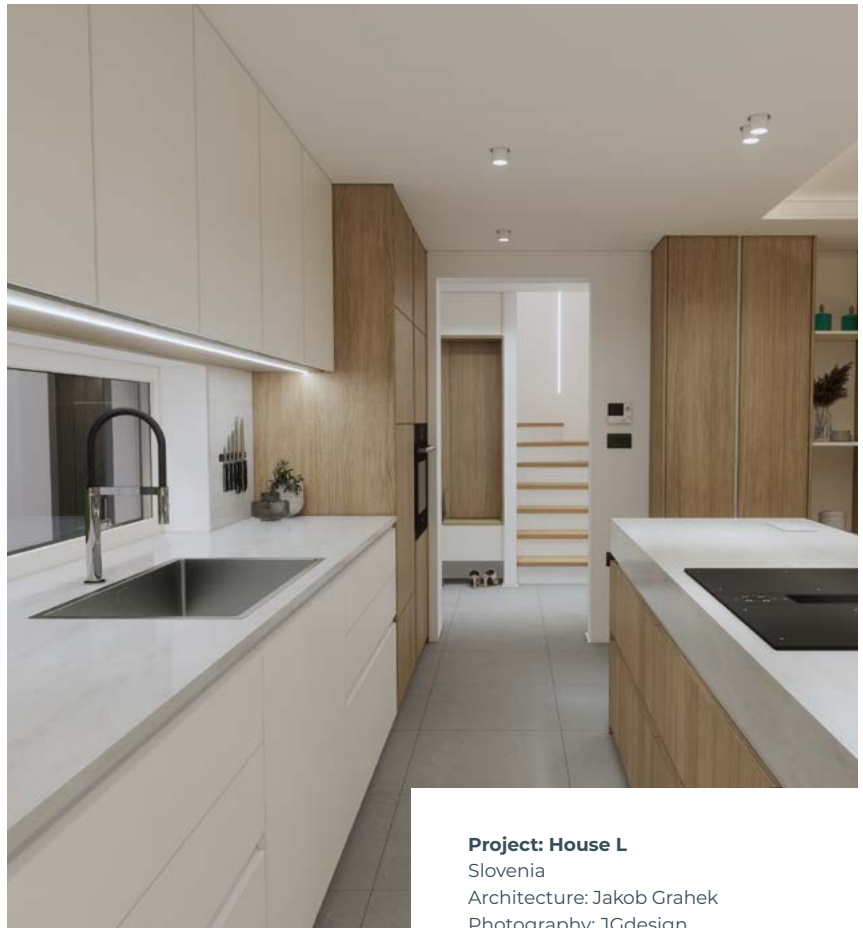

**Project: House L**

Slovenia  
Architecture: Jakob Grahek  
Photography: JGdesign



**Project: Jaz in the City Vienna**  
Vienna, Austria



# Hotel

In a world of demanding hoteliers, Kerrock has become an indispensable partner. With its many colours, dimensions and invisible joints, it offers virtually unlimited design possibilities. Ease of cleaning and maintenance adds the icing on the cake to a well-thought-out investment.

*APPLICATION: Reception counters/lobby bar counters/ restaurant dividers/table tops/wall cladding/shelves/racks/bathroom elements/table tops/wall cladding/vanity tops/facades/pool bars/wellness cladding/countertops/shelves/racks/decorative elements*

# Hotel

In einer Welt der anspruchsvollen Hoteliers ist Kerrock zu einem unverzichtbaren Partner geworden. Mit seinen vielen Farben, Dimensionen und unsichtbaren Fugen bietet es praktisch unbegrenzte unsichtbare Verbindungen. Leichte Reinigung und Pflege sind die Basis einer gut durchdachten Investition.

*EINSATZ: Empfangstresen/Lobby-Bartresen/ Restauranttrennwände/Tischplatten/Wandverkleidungen/ Regale/Ablagen/Badezimmerelemente/Tischplatten/ Wandverkleidungen/Waschtischplatten/Fassaden/ Poolbars/Fassaden/Wellnessverkleidungen/ Arbeitsplatten/Regale/Ablagen/dekorative Elemente*

# Hôtel

Dans un monde d'hôteliers exigeants, Kerrock est devenu un partenaire indispensable. Grâce à ses joints invisibles, ses nombreuses couleurs et dimensions, il offre des possibilités de conception pratiquement illimitées. La facilité de nettoyage et d'entretien est la cerise sur le gâteau d'un investissement bien pensé.

*UTILISATION : Comptoirs de réception/comptoirs et pistes de Bar/Ciels de Bar/passe-plats/dessus de table/habillage muraux/étagères/éléments de salle de bains/ Ciels de Bar/ façades/ Pool-Bar/meubles/rangements/espaces de bien-être/éléments décoratifs*



**Hotel Princess 5\***  
Jastrebarsko, Croatia

**Project: Oxford**

Romania

Architecture: Phenomena laboratory

Photography: Vlad Patru





**Project: Cronos MED**

Architecture: Egnilibrium Design

Photography: Tudor Cucu

Installation: Romtexim





# Medicine

Clean rooms are quite easy to achieve with Kerrock. It can be found in medicine, pharmaceuticals and anywhere that requires antibacterial surfaces that are also easy to clean and maintain.

*APPLICATION: Reception counters/outpatient countertops/ medical countertops/"soft" lab countertops/wall cladding/ sanitary walls/quickcube bathrooms and cladding/clean room walls – operating theatres/bathroom elements*

# Medizin

Saubere Räume sind mit Kerrock ganz einfach zu erreichen. Es kommt in der Medizin, der Pharmazie und überall dort zum Einsatz, wo antibakterielle Oberflächen benötigt werden, die zudem leicht zu reinigen und zu pflegen sein sollten.

*EINSATZ: Empfangstresen/Ambulante Tresen/ Ambulanzthecken/weiche Labortheken/ Wandverkleidungen/Sanitärwände/Quickcube Bäder und Verkleidungen/Reinraumwände – Operationssäle/ Badezimmerelemente*

# Médecine

Avec Kerrock, il est facile d'obtenir des espaces propres. On le trouve dans les établissements de santé, les officines et partout où l'on a besoin de surfaces antibactériennes faciles à nettoyer et à entretenir.

*UTILISATION : Comptoirs d'accueil/chariots/dessertes/ paillasse sèches. paillasse humides/ comptoirs chirurgicaux//revêtements muraux/parois sanitaires/ salles de bains "quickcube"/écrans de discrétion/ Habillages de blocs opératoires/éléments de salle de bains*

**Project: Cronos MED**  
Architecture: Equilibrium Design  
Photography: Tudor Cucu  
Installation: Romtexim



42



**Project: Recepcia zubnej ambulancie  
DominoDent**  
Slovakia  
Architecture: Dizajne s.r.o.  
Photography: Dizajne s.r.o.  
Installation: Dizajne s.r.o.





**Čelesnik Dental Centre**  
Bled, Slovenia



**Izola Emergency Centre**  
Slovenia

# Retail

Retail needs lots of sales. And every little bit counts, because consumers shop with all their senses. Bewitch your customers at first sight, touch and emotion. When it comes to your business, we think of everything.

*APPLICATION: Reception counters/decorative elements/vanity tops/wall cladding/bathroom elements/sanitary walls*

# Einzelhandel

Der Einzelhandel braucht viele Verkäufe. Und jede Kleinigkeit zählt, denn die Verbraucher kaufen mit allen Sinnen ein. Verzaubern Sie ihn auf den ersten Blick, bei Berührung und Gefühl. Wenn es um Ihr Unternehmen geht, denken wir an alles.

*EINSATZ: Empfangstresen/dekorative Elemente/Toilettentresen/Wandverkleidungen/Badezimmerelemente/Sanitärwände*

# Commerce de détail

Le commerce de détail a besoin de beaucoup de ventes. Et chaque petit détail compte, car les consommateurs font leurs achats avec tous leurs sens. Ensorcellez-le au premier regard, au premier toucher et à la première émotion. Lorsqu'il s'agit de votre entreprise, nous pensons à tout.

*UTILISATION : Comptoirs d'accueil/éléments décoratifs/comptoirs de toilettes/revêtements muraux/éléments de salle de bains/parois sanitaires*



*Timeless beauty*

**Project: Cronos by the Sea**  
Constanta, Romunija  
Installation: SC ROMTEXIM SRL



**Flower boutique Floriday**  
Moscow City, Russia  
Design: RUUMZ Studio  
Photography: E. Kulibaba





**Project: JEM Urbanwear**  
Konstanz, Germany  
Design: Studio DLF  
Photography: Daniele Luciano Ferrazzano

47

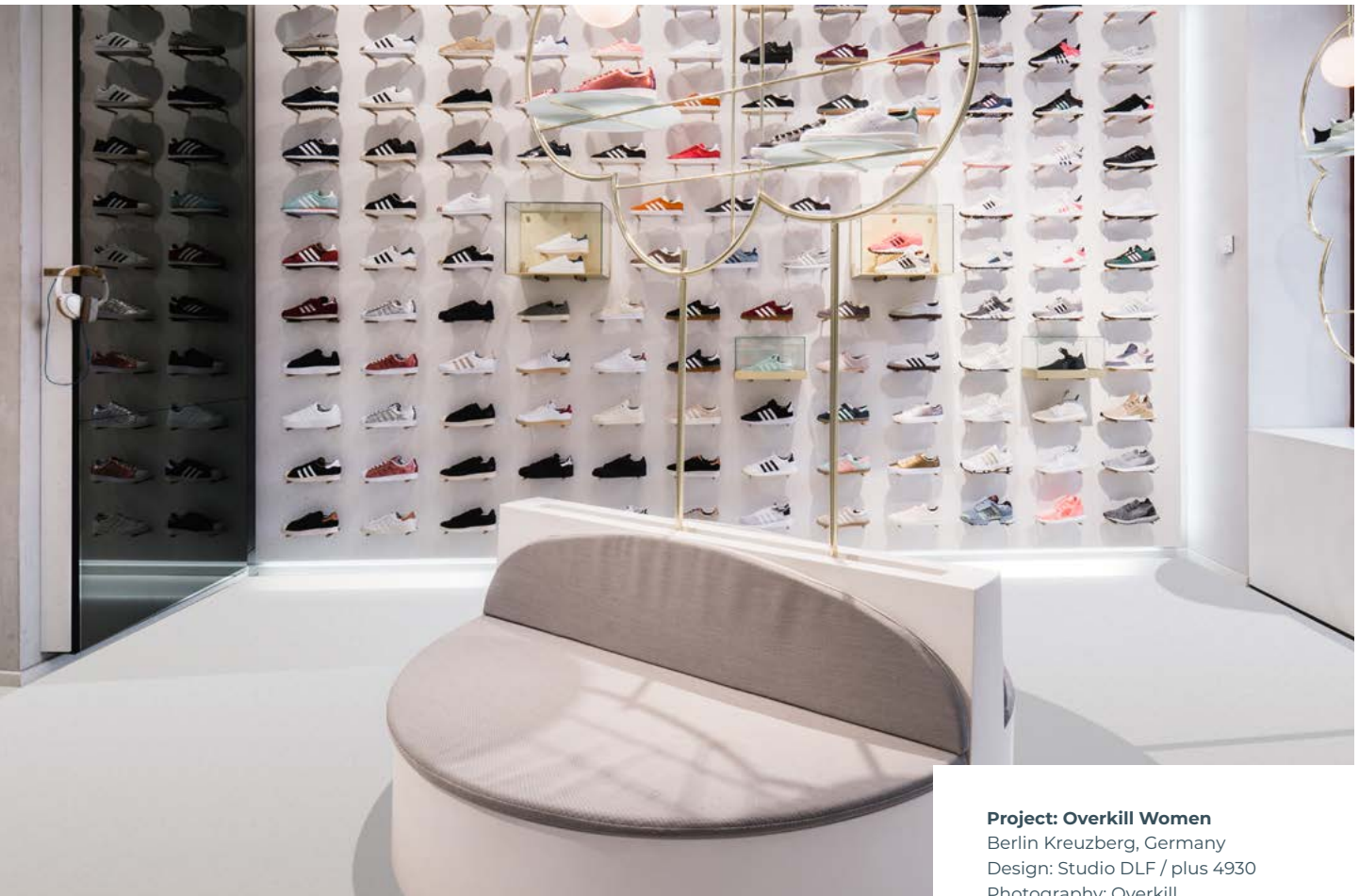

**Project: Overkill Women**  
Berlin Kreuzberg, Germany  
Design: Studio DLF / plus 4930  
Photography: Overkill



**Project: Apartment Złota 44, Warsaw**

Warsaw, Poland

Fabricator: RC Design sp. z o.o.

Design: Hernan Gomez

Photography: RC Design sp. z o.o.





# Business premises

Business premises. Whether it's a modern office environment, a stylish conference room or a relaxing meeting room, our team of experts will make your business space radiate professionalism and success with top-quality Kerrock materials.

*APPLICATION: Reception areas/lobbies/offices/meeting/rooms/decorative coverings/toilets*

# Geschäftsräume

Geschäftsräume. Ob es sich um eine moderne Büroumgebung, einen stilvollen Konferenzraum oder einen entspannenden Besprechungsraum handelt, unser Team von Experten lässt Ihre Geschäftsräume mit hochwertigen Kerrock Materialien Professionalität und Erfolg ausstrahlen.

*EINSATZ: Empfangsbereiche/Lobbys/Büros/Konferenzräume/dekorative Verkleidungen/Toiletten*

# Espaces professionnels

Espaces professionnels. Qu'il s'agisse d'un environnement de bureau moderne, d'une salle de conférence élégante ou d'une salle de réunion relaxante, notre équipe d'experts fera en sorte que votre espace professionnel rayonne de professionnalisme et de succès grâce à des matériaux Kerrock de première qualité.

*UTILISATION : Réceptions/halls d'entrée/bureaux/salles de réunion/revêtements décoratifs/toilettes*

**Projekt: Reception Desk**

Arkkitehtitoimisto Olla Oy, Finska  
Architecture: Tiina Lipponen, interior architect  
Manufacturer: Helsingin Mittapuu Oy  
Photography: Tea Ellala



50

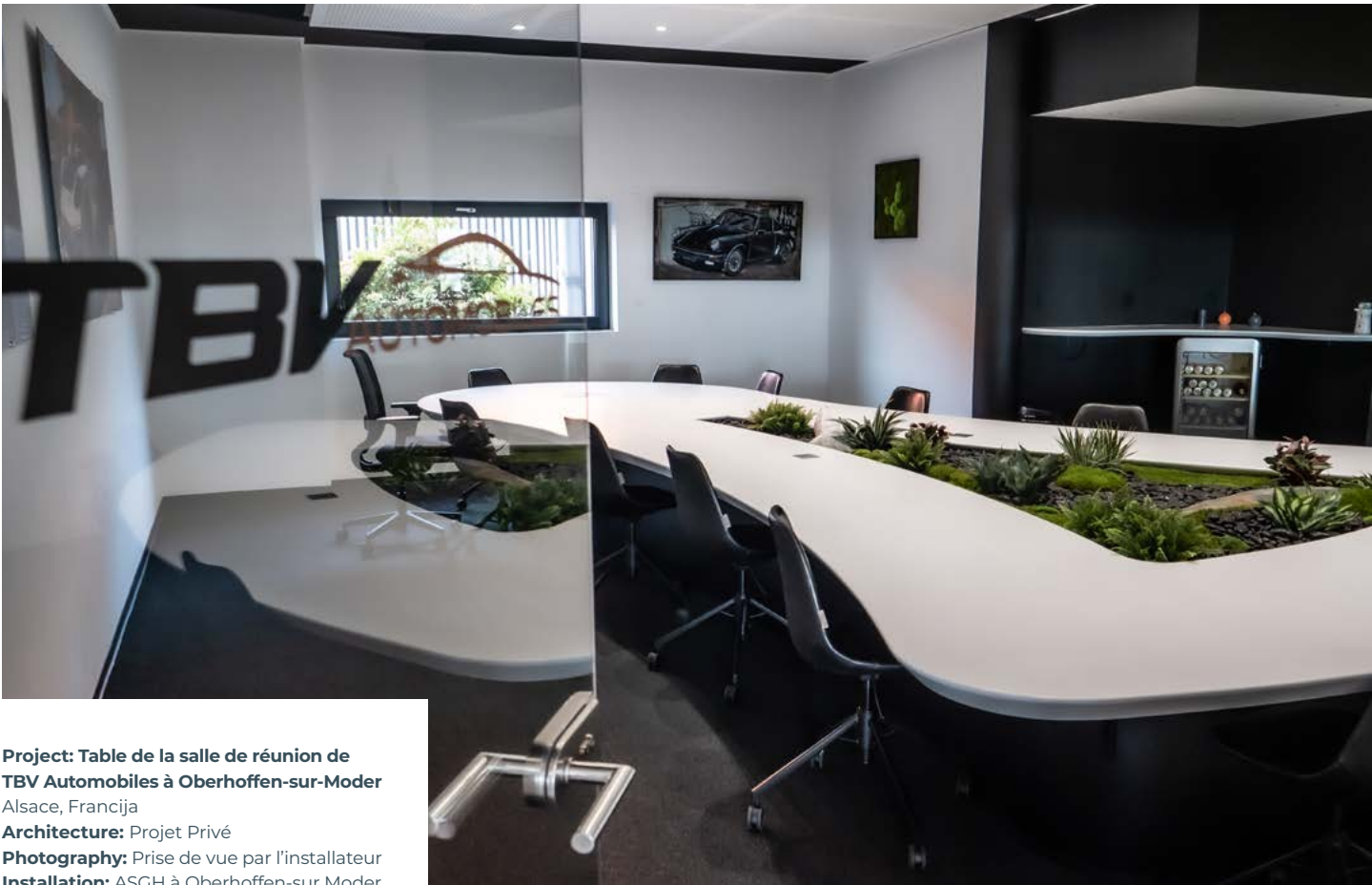

**Project:** Table de la salle de réunion de  
**TBV Automobiles à Oberhoffen-sur-Moder**  
Alsace, Francija  
**Architecture:** Projet Privé  
**Photography:** Prise de vue par l'installateur  
**Installation:** ASGH à Oberhoffen-sur Moder





**Project: Magyar Pénzmúzeum és látogatóközpont**

Hungary

Architecture: Narmer Építészeti Stúdió

Photography: Alexandra Szűcs

Photography

Installation: Nezozen KFT



# Public institutions

When you place public space in local architecture, its key characteristic is absolute functionality and sustainability. The reasons why Kerrock is becoming the gold standard in this field.

# Öffentliche Einrichtungen

Wenn Sie den öffentlichen Raum in die lokale Architektur einbinden, ist sein wichtigstes Merkmal absolute Funktionalität und Nachhaltigkeit. Die Gründe, warum Kerrock sich zum Goldstandard in diesem Bereich entwickelt hat.

# Institutions publiques

Lorsque vous placez l'espace public dans l'architecture locale, sa principale caractéristique est sa fonctionnalité absolue et sa durabilité. Les principales raisons pour lesquelles Kerrock est en train de devenir la référence dans ce domaine.

**MOL Cikava**  
Grosuplje, Slovenija



54



**Petrol Barje**  
Ljubljana, Slovenia

**Projekt: Etele Plaza**

Hungary

Photography: SVM Sortiment Vállalkozási KFT

Installation: Aleksandra Szűcs Photography





**Wellnes hotel Rivera**  
Portorož, Slovenia





# Wellness

Water dancing on the surface of infinite shapes.  
A dance of relaxation of mind and body. Kerrock – a place  
of well-being that exceeds expectations every time.

# Wellness

Fühlen sie wie das Wasser auf unendlichen Formen tanzt.  
Ein Tanz der Entspannung für Geist und Körper. Kerrock  
– ein Ort des Wohlbefindens, der die Erwartungen jedes  
Mal übertrifft.

# Bien-être

L'eau danse sur des formes infinies. La danse de  
relaxation du corps et de l'esprit. Kerrock siège de bien-  
être qui dépasse à chaque fois les attentes.

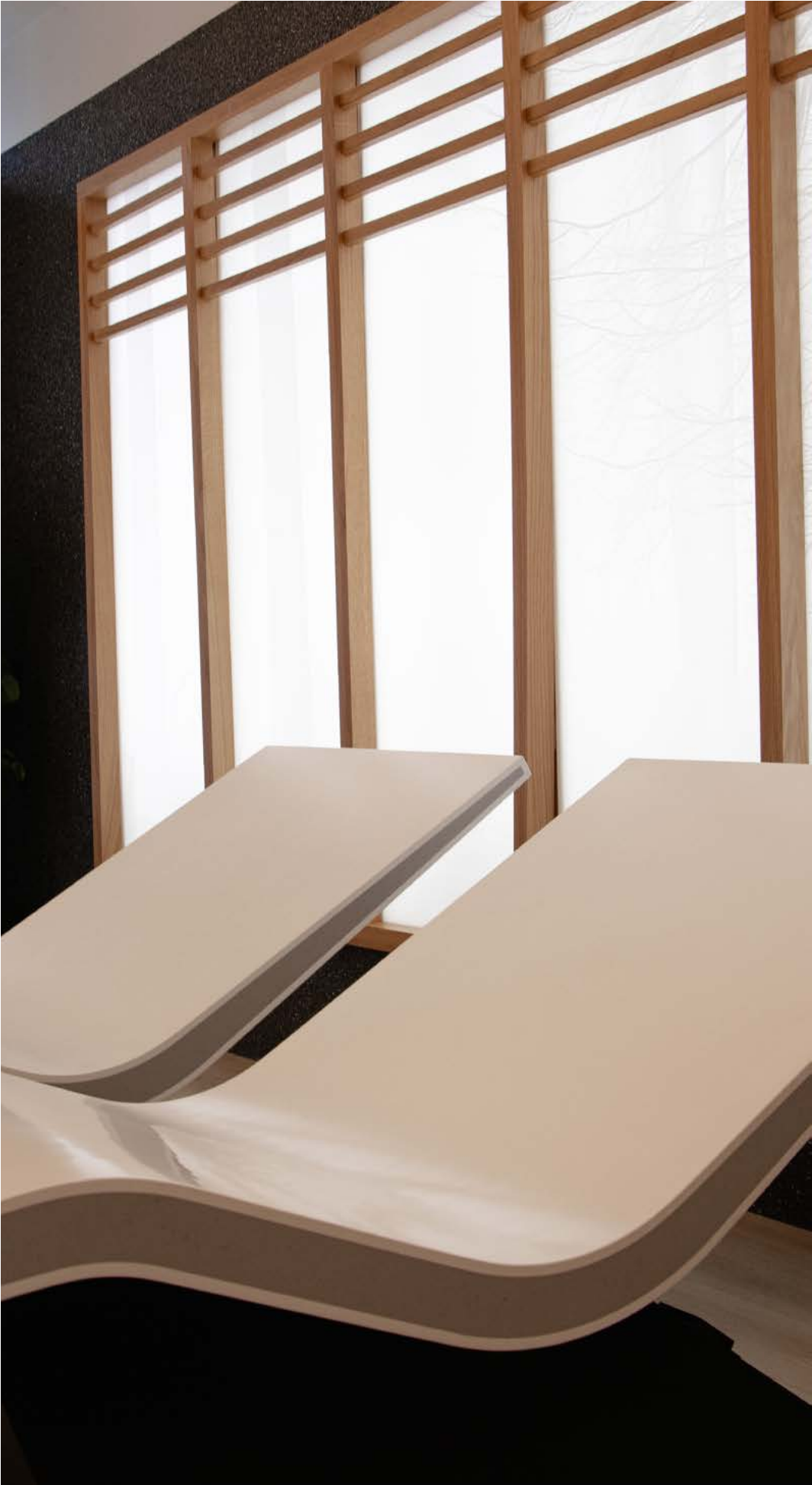



# Nautics

Water resistance, functional aesthetics and IMO-certification. Nautics just loves it!

*APPLICATION: Kitchen countertops/sinks/kitchen wall cladding/vanity tops/bathroom sinks/bathroom wall cladding/table tops*

# Nautik

Wasserdicht, funktionelle Ästhetik und IMO-zertifiziert. Die Nautiker lieben es einfach!

*EINSATZ: Küchenarbeitsplatten/Spülbecken/  
Wandverkleidungen für Küchen/  
Badezimmerarbeitsplatten/Waschbecken für  
Badezimmer/Wandverkleidungen für Badezimmer/  
Tischplatten*

# Nautisme

Résistance à l'eau, esthétique fonctionnelle et certification IMO , les chantiers navals l'adorent!

*UTILISATION : Comptoirs de cuisine/évier/revêtements muraux de cuisine/comptoirs de salle de bain/lavabos de salle de bain/revêtements muraux de salle de bain/dessus de table*





**Elan Yachts**  
Slovenia

**Elan Yachts**  
Slovenia



62

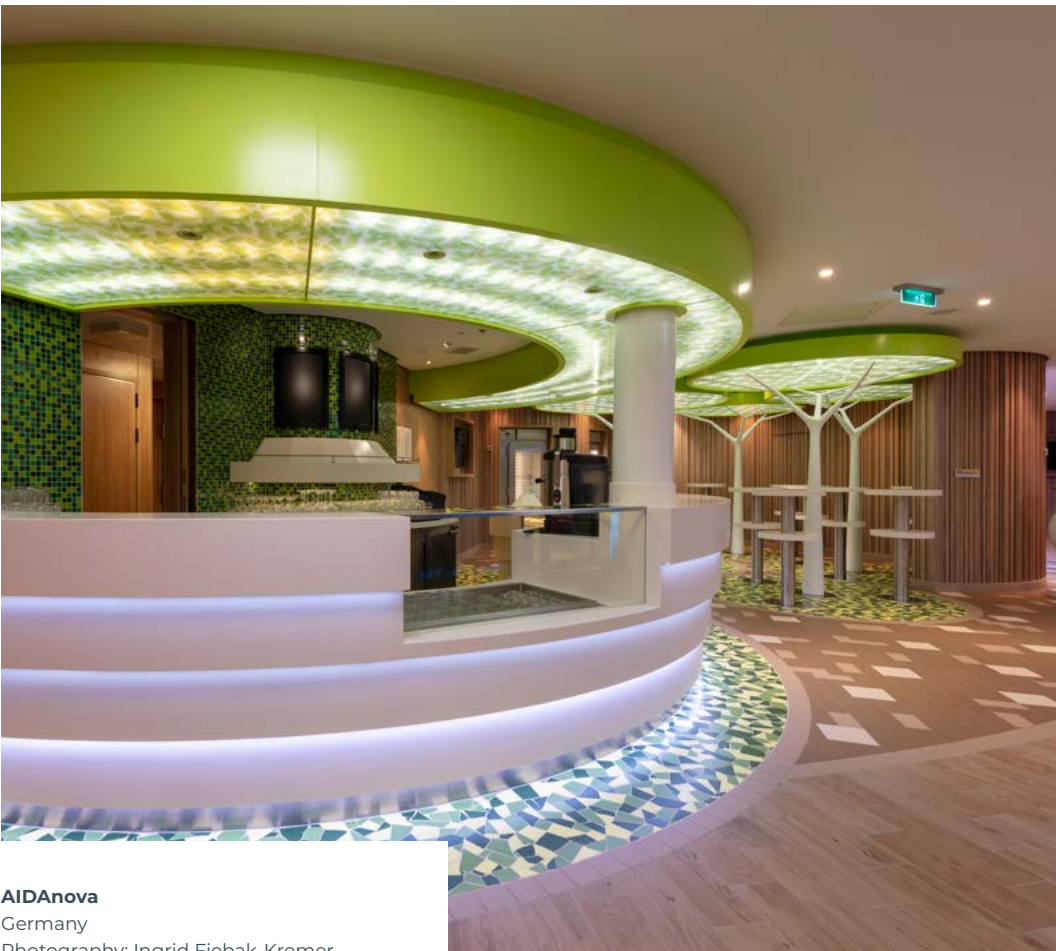

**AIDAnova**  
Germany  
Photography: Ingrid Fiebak-Kremer





# Caravanning

Holidays, travel and a sense of freedom in a limited space.  
A paradox that only few materials can match.  
A sophisticated design that ensures better utilisation  
with high aesthetics. Heat and water resistance. Kerrock.

*APPLICATION: Vanity tops/kitchen countertops/wall  
cladding/decorative elements*

# Caravaning

Urlaub, Reisen und ein Gefühl von Freiheit auf  
begrenztem Raum. Ein Paradox, das nur wenige  
Materialien bieten können.  
Ein ausgeklügeltes Design, das eine bessere Nutzung  
mit hoher Ästhetik gewährleistet. Hitze- und  
wasserbeständig. Kerrock.

*EINSATZ: Waschtischplatten/Küchentheken/  
Wandverkleidungen/Dekorationselemente*

# Caravaning

Vacances, voyages et sentiment de liberté dans un  
espace restreint. Un paradoxe que peu de matériaux  
peuvent égaler.  
Un design sophistiqué qui assure une meilleure  
utilisation et une grande esthétique. Résistance à la  
chaleur et à l'eau. Kerrock.

*UTILISATION : Plans de toilette/comptoirs de cuisine/  
revêtements muraux/éléments décoratifs*







**Adria Mobil, Supersonic**  
Slovenia



**Adria Mobil, Astella**  
Slovenia







# **Experience of the past has shaped it into the material of the future.**

DIE ERFAHRUNGEN DER  
VERGANGENHEIT HABEN ES ZUM  
MATERIAL DER ZUKUNFT GEFORMT.

LES EXPÉRIENCES DU PASSÉ L'ONT  
FAÇONNÉ POUR EN FAIRE LE MATÉRIAU  
DE L'AVENIR.



**Exterior**  
Äußeres  
Extérieur



**Project: Villa Olimp**

Olimp, Romania

Architecture: Phenomena laboratory

Photography: Cosmin Dragomir



# The first impression maker

The connector of the material and emotional world. A language of values, aesthetics and culture. A Kerrock-enhanced building creates a lasting footprint. For future generations.

*APPLICATION: Facades/outdoor furnishings/benches/table tops/decorative elements/bathing areas*

# Der erste Eindruck

Die Verbindung zwischen der materiellen und der emotionalen Welt. Eine Sprache der Werte, der Ästhetik und der Kultur. Ein Gebäude mit Kerrock hinterlässt einen bleibenden Eindruck. Für zukünftige Generationen.

*EINSATZ: Fassaden/Außenmobiliar/Bänke/Tischplatten/dekorative Elemente/Badebereiche*

# Créateur de la première impression

Le lien entre le monde matériel et le monde émotionnel. Expression des valeurs, de l'esthétique et de la culture. Le bâtiment avec Kerrock crée une empreinte durable. Pour les générations futures.

*UTILISATION : Façades/équipement extérieur/bancs/dessus de table/éléments décoratifs/zones de baignade*

**Villa Great White**  
Korčula, Croatia  
Photography: Robert Potokar

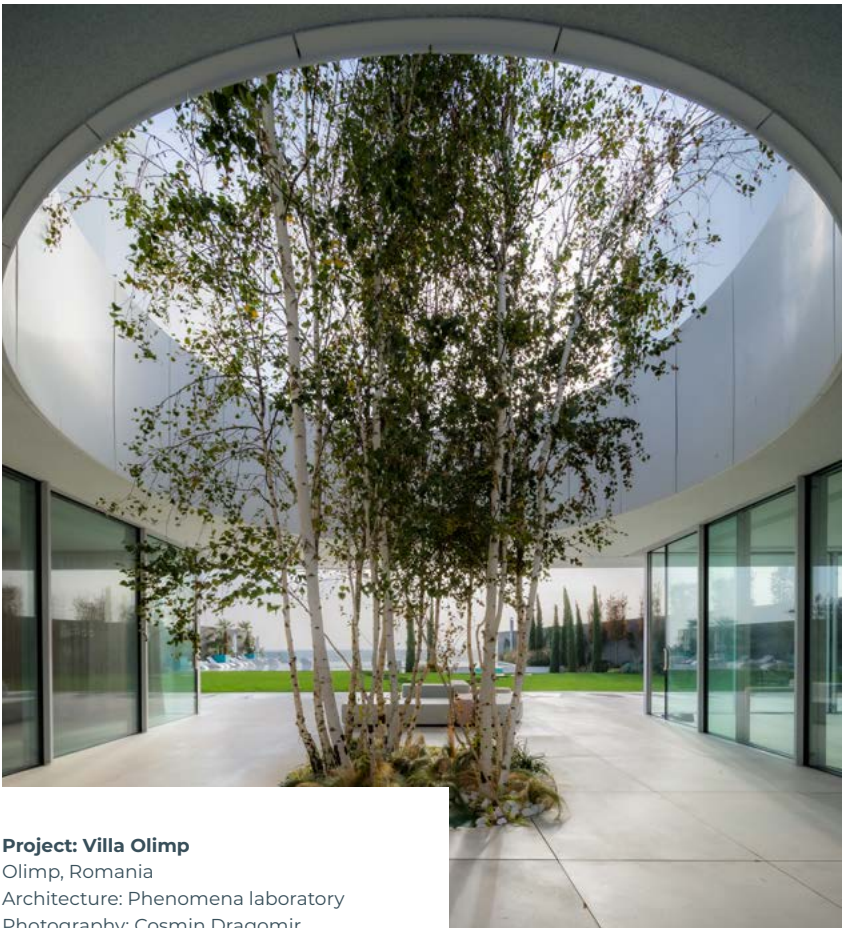
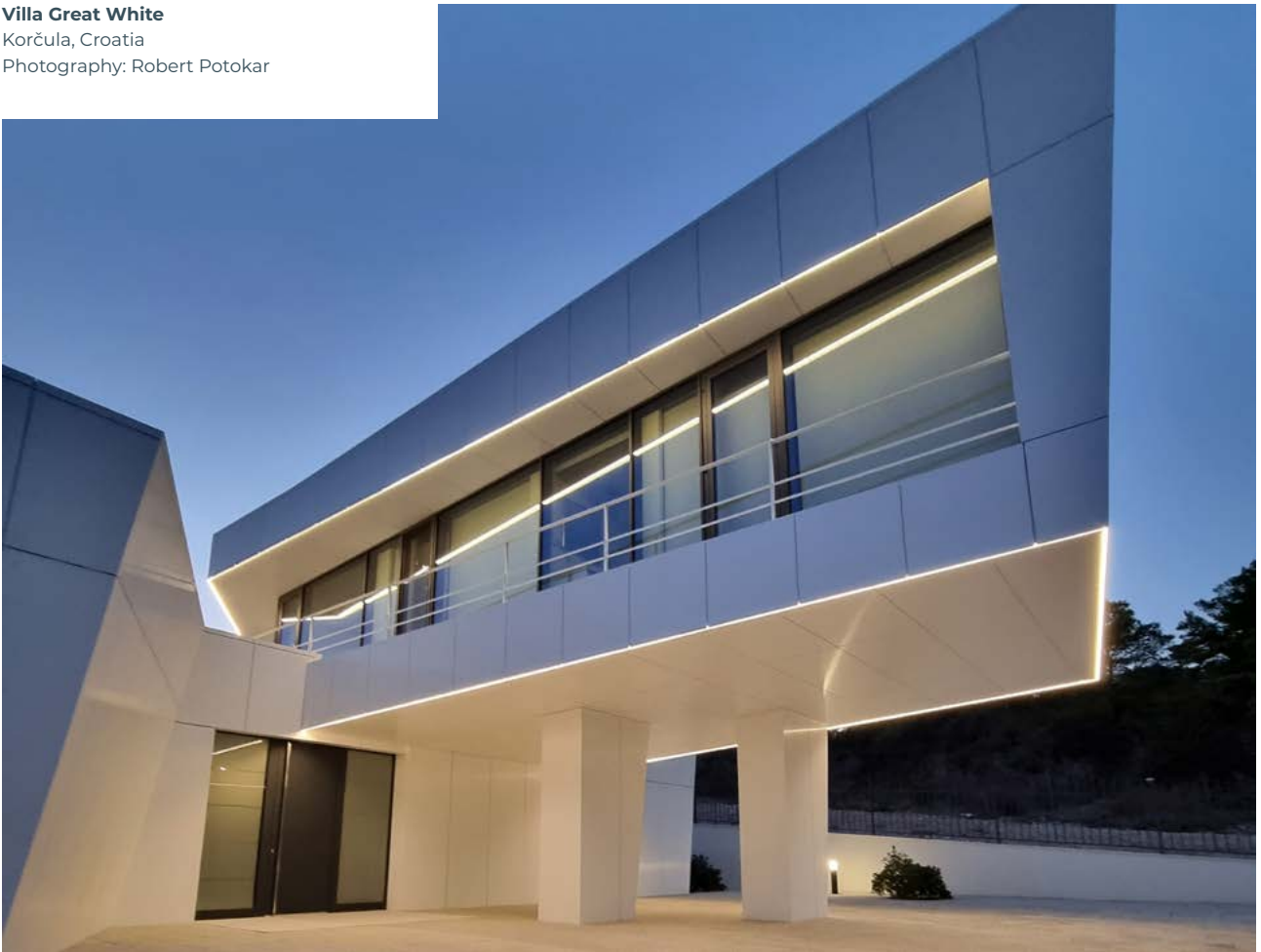

**Project: Villa Olimp**  
Olimp, Romania  
Architecture: Phenomena laboratory  
Photography: Cosmin Dragomir





**Project: Villa Olimp**

Olimp, Romania

Architecture: Phenomena laboratory

Photography: Cosmin Dragomir



**Project: Villa Olimp**

Olimp, Romania

Architecture: Phenomena laboratory

Photography: Cosmin Dragomir



**Villa Great White**  
Korčula, Croatia  
Photography: Robert Potokar





# **What colour is your residence?**

WELCHE FARBE HAT IHR ZUHAUSE?

QUELLE EST LA COULEUR DE VOTRE  
RÉSIDENCE ?



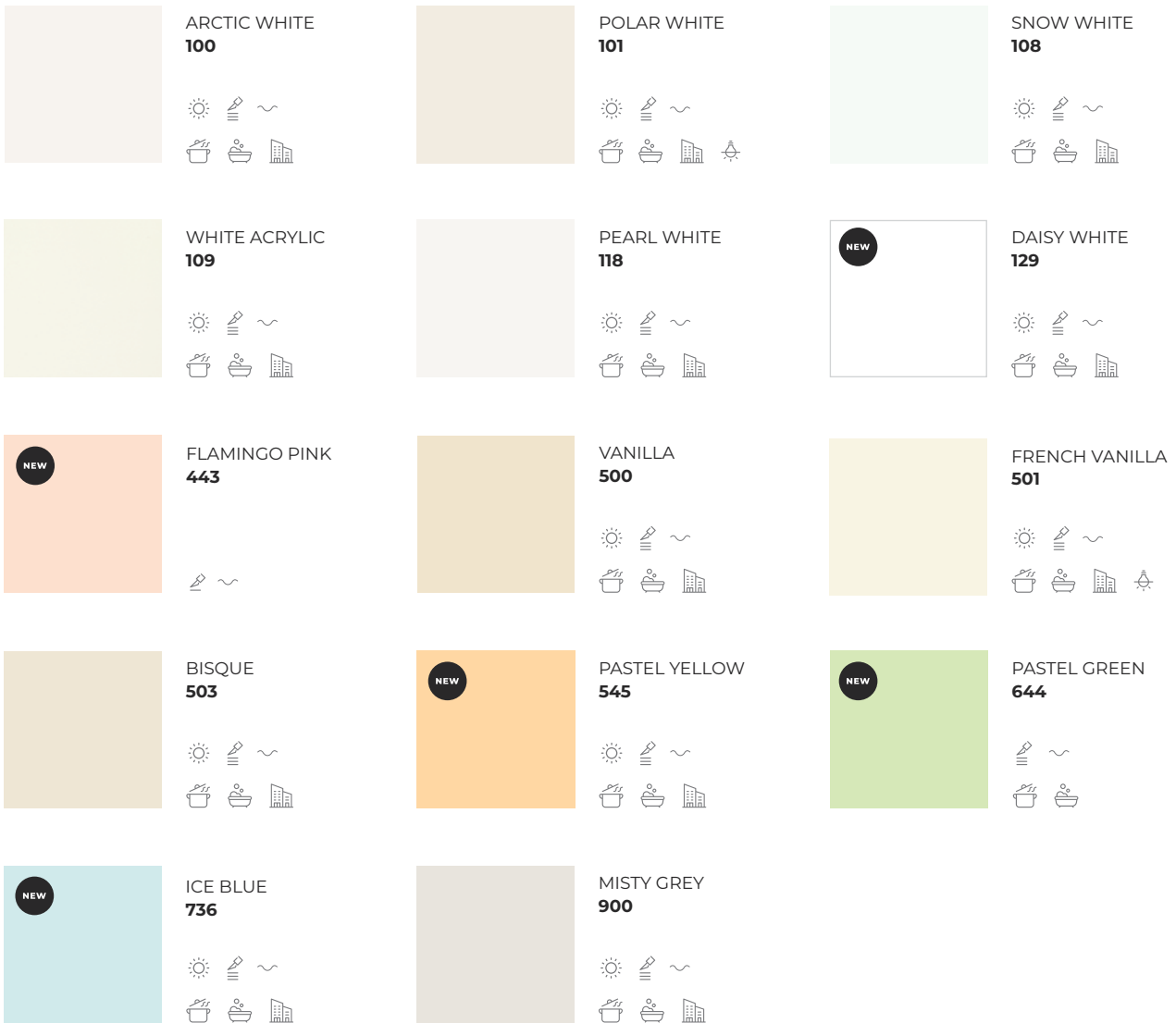

**Colours**  
**Farben**  
**Couleurs**

**Uni light**



 UV resistance – colour change of less than 5 ΔE in 10 years. / UV-Beständigkeit – Farbveränderung von weniger als 5 ΔE in 10 Jahren. / Résistance aux UV – changement de couleur inférieur à 5 ΔE en 10 ans.

 Noticeable traces after intensive use. / Fühlbare Spuren nach intensivem Gebrauch. / Traces visibles après une utilisation intensive.

 Slight traces of heavy use, visible from a certain angle. / Gute Tiefziehooption, das Material kann bis zu dem im technischen Datenblatt angegebenen Krümmungsradius tiefgezogen werden. / Légères traces d'utilisation intensive, visibles sous un certain angle.

 Good thermoforming option, the material can be thermoformed up to the radius of curvature shown in the technical data sheet catalogue for Kerrock processing. It also allows you to create 3-dimensional shapes, although complex shapes can show slight discolouration on the curve. / Bonne option de thermoformage, le matériau peut être thermoformé jusqu'au rayon de courbure indiqué dans le catalogue technique de traitement des matériaux kerrock. Il vous permet également de créer des formes tridimensionnelles, bien que pour des formes complexes, une légère décoloration sur la courbe peut être visible.

 Designed for kitchen areas: Countertops with kitchen sink, wall cladding, tables, kitchen islands, shelves, racks. / Entworfen für den Küchenbereich: Arbeitsplatten mit Spüle, Wandverkleidungen, Tische, Kücheninseln, Regale, Ablagen. / Conçu pour les cuisines : Comptoirs avec évier, revêtements muraux, tables, îlots de cuisine, étagères, supports.

 Designed for bathrooms: Vanity tops, shelves, racks, shelving, wall cladding – an alternative to ceramic tiles. / Entworfen für Badezimmer: Waschtischplatten mit Becken, Ablagen, Regalen, Ablageflächen, Wandverkleidungen – eine Alternative zu Keramikfliesen. / Conçu pour les salles de bains : Comptoirs de lavabos avec vasques, étagères, supports, rayons, revêtements muraux – une alternative aux plaques de céramique.

 For outdoor use: Facades, outdoor furnishings, benches, table tops, decorative elements. / Für die Verwendung im Freien: Fassaden, Außenmobiliar, Bänke, Tischplatten, dekorative Elemente. / Pour l'extérieur: Façades, équipement extérieur, bancs, plaques de table, éléments décoratifs.

 Translucency – semi-transparent colour when backlit. / Transluzenz – halbttransparente Farbe, wenn sie hinterleuchtet werden. / Translucidité – couleur semi-transparente lorsqu'elle est rétroéclairée.

**Uni dark**



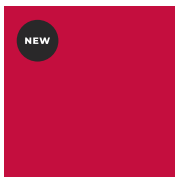

**RUBY PINK**  
**441**

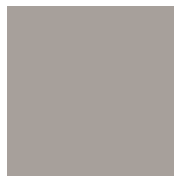

**GREY QUARTZITE**  
**513**



**SANDSTONE**  
**514**

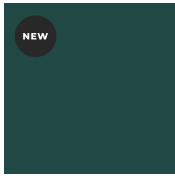

**FOREST GREEN**  
**645**



**ADRIATIC BLUE**  
**729**

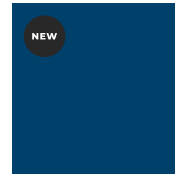

**INDIGO**  
**737**

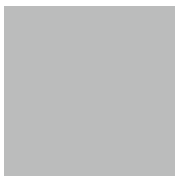

**ASH GREY**  
**901**



**BLACK**  
**909**



**GYPSUM**  
**921**



**WATER STONE**  
**922**



**CHARCOAL**  
**923**



**BEIGEING**  
**924**





 UV resistance – colour change from 5 ΔE to 10 ΔE in 10 years. / UV-Beständigkeit – Farbveränderung von 5 ΔE auf 10 ΔE in 10 Jahren. / Résistance aux UV – Changement de couleur de 5 ΔE à 10 ΔE en 10 ans.

 UV resistance – colour change of less than 5 ΔE in 10 years. / UV-Beständigkeit – Farbveränderung von weniger als 5 ΔE in 10 Jahren. / Résistance aux UV – changement de couleur inférieur à 5 ΔE en 10 ans.

 Noticeable traces after intensive use. / Fühlbare Spuren nach intensivem Gebrauch. / Traces visibles après une utilisation intensive.

 Minor traces after heavy use. / Leichte Gebrauchsspuren. / Traces mineures d'utilisation intensive.

 Slight traces of heavy use, visible from a certain angle. / Leichte Gebrauchsspuren, die aus einem bestimmten Winkel sichtbar sind. / Légères traces d'utilisation intensive, visibles sous un certain angle.

 Good thermoforming option, the material can be thermoformed up to the radius of curvature shown in the technical data sheet catalogue for Kerrock processing. It also allows you to create 3-dimensional shapes, although complex shapes can show slight discolouration on the curve. / Gute Tiefziehooption, das Material kann bis zu dem im technischen Datenblatt angegebenen Krümmungsradius tiefgezogen werden Katalog für die Verarbeitung von Kerrock-Material. Es ermöglicht Ihnen auch, 3-dimensionale Formen zu erstellen, obwohl bei komplexen Formen eine leichte Farbänderung am Radius auffallen kann. / Bonne option de thermoformage, le matériau peut être thermoformé jusqu'au rayon de courbure indiqué dans le catalogue technique de traitement des matériaux kerrock. Il vous permet également de créer des formes tridimensionnelles, bien que pour des formes complexes, une légère décoloration sur la courbe peut être visible.

 Designed for kitchen areas: Countertops with kitchen sink, wall cladding, tables, kitchen islands, shelves, racks. / Entworfen für den Küchenbereich: Arbeitsplatten mit Spüle, Wandverkleidungen, Tische, Kücheninseln, Regale, Ablagen. / Conçu pour les cuisines : Comptoirs avec évier, revêtements muraux, tables, îlots de cuisine, étagères, supports.

 Designed for bathrooms: Vanity tops, shelves, racks, shelving, wall cladding – an alternative to ceramic tiles. / Entworfen für Badezimmer: Waschtischplatten mit Becken, Ablagen, Regalen, Ablageflächen, Wandverkleidungen – eine Alternative zu Keramikfliesen. / Conçu pour les salles de bains : Comptoirs de lavabos avec vasques, étagères, supports, rayons, revêtements muraux – une alternative aux plaques de céramique.

 For outdoor use: Facades, outdoor furnishings, benches, table tops, decorative elements. / Für die Verwendung im Freien: Fassaden, Außenmobiliar, Bänke, Tischplatten, dekorative Elemente. / Pour l'extérieur: Façades, équipement extérieur, bancs, plaques de table, éléments décoratifs.

**Granit**



WOLLASTONITE  
1076

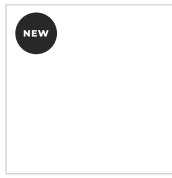

BRILLIANTE  
1080



DOLOMITE GRAIN  
1087



ICELAND  
1090



SALT AND PEPER  
1091

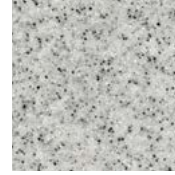

PYRITE  
1093

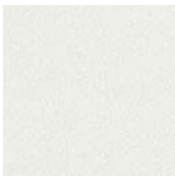

APENINO  
1193



DESERT GOLD  
5080



BASALT  
5195



CRYOLITE  
5196



HEDENBERGIT  
9011

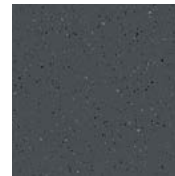

KYANITE  
9081



MOLIBDENITE  
9095

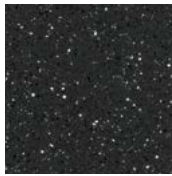

ONYX  
9099



UV resistance – colour change from 5 ΔE to 10 ΔE in 10 years. / UV-Beständigkeit – Farbveränderung von 5 ΔE auf 10 ΔE in 10 Jahren. / Résistance aux UV – Changement de couleur de 5 ΔE à 10 ΔE en 10 ans.

UV resistance – colour change of less than 5 ΔE in 10 years. / UV-Beständigkeit – Farbveränderung von weniger als 5 ΔE in 10 Jahren. / Résistance aux UV – changement de couleur inférieur à 5 ΔE en 10 ans.

Noticeable traces after intensive use. / Fühlbare Spuren nach intensivem Gebrauch. / Traces visibles après une utilisation intensive.

Minor traces after heavy use. / Leichte Gebrauchsspuren. / Traces mineures d'utilisation intensive.

Slight traces of heavy use, visible from a certain angle. / Leichte Gebrauchsspuren, die aus einem bestimmten Winkel sichtbar sind. / Légères traces d'utilisation intensive, visibles sous un certain angle.

Good thermoforming option, the material can be thermoformed up to the radius of curvature shown in the technical data sheet catalogue for Kerrock processing. It also allows you to create 3-dimensional shapes, although complex shapes can show slight discolouration on the curve. / Gute Tiefziehooption, das Material kann bis zu dem im technischen Datenblatt angegebenen Krümmungsradius tiefgezogen werden. Katalog für die Verarbeitung von Kerrock-Material. Es ermöglicht Ihnen auch, 3-dimensionale Formen zu erstellen, obwohl bei komplexen Formen eine leichte Farbänderung am Radius auffallen kann. / Bonne option de thermoformage, le matériau peut être thermoformé jusqu'au rayon de courbure indiqué dans le catalogue technique de traitement des matériaux kerrock. Il vous permet également de créer des formes tridimensionnelles, bien que pour des formes complexes, une légère décoloration sur la courbe peut être visible.

Designed for kitchen areas: Countertops with kitchen sink, wall cladding, tables, kitchen islands, shelves, racks. / Entworfen für den Küchenbereich: Arbeitsplatten mit Spüle, Wandverkleidungen, Tische, Kücheninseln, Regale, Ablagen. / Conçu pour les cuisines : Comptoirs avec évier, revêtements muraux, tables, îlots de cuisine, étagères, supports.

Designed for bathrooms: Vanity tops, shelves, racks, shelving, wall cladding – an alternative to ceramic tiles. / Entworfen für Badezimmer: Waschtischplatten mit Becken, Ablagen, Regalen, Ablageflächen, Wandverkleidungen – eine Alternative zu Keramikfliesen. / Conçu pour les salles de bains : Comptoirs de lavabos avec vasques, étagères, supports, rayons, revêtements muraux – une alternative aux plaques de céramique.

For outdoor use: Facades, outdoor furnishings, benches, table tops, decorative elements. / Für die Verwendung im Freien: Fassaden, Außenmobiliar, Bänke, Tischplatten, dekorative Elemente. / Pour l'extérieur: Façades, équipement extérieur, bancs, plaques de table, éléments décoratifs.

Translucency – semi-transparent colour when backlit. / Transluzenz – halbttransparente Farbe, wenn sie hinterleuchtet werden. / Translucidité – couleur semi-transparente lorsqu'elle est rétroéclairée.

Colour containing some recycled material. / Farbe mit einem Anteil an recyceltem Material. / Couleur contenant des matériaux recyclés.

The background of the image is a classic terrazzo pattern, featuring a light-colored matrix with numerous small, dark, irregularly shaped chips or aggregates scattered throughout. The overall appearance is speckled and textured.

**Terrazzo**

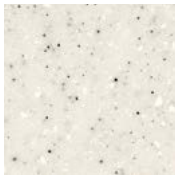

QUARTZ  
1050

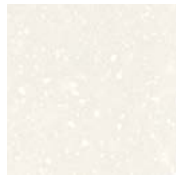

ARAGONITE  
1052

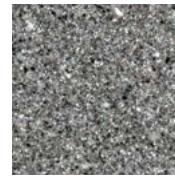

GRANULITE  
1055



SUNRISE  
1157

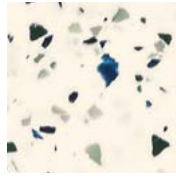

AZZURE  
1158



ARGENTO  
1159

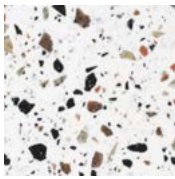

VENETIAN  
1160



DIAMOND  
1250



HALITE  
1251



CRUSHED ICE  
1252

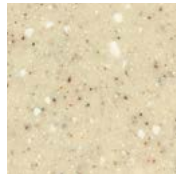

CALCITE  
5053



ALBIT  
5061



BOTTICINO  
5250



PERLATO ROYAL  
5251

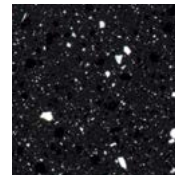

OBSIDIAN  
9050



SELENITE  
9250



MOONLIGHT  
9251

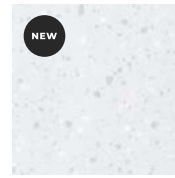

ANDESITE  
9252



CHROMITE  
9253

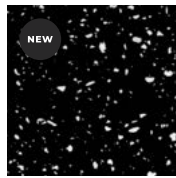

SNOWFALL  
9257



UV resistance – colour change from 5 ΔE to 10 ΔE in 10 years. /  
UV-Beständigkeit – Farbveränderung von 5 ΔE auf 10 ΔE in 10 Jahren. /  
Résistance aux UV – Changement de couleur de 5 ΔE à 10 ΔE en 10 ans.

UV resistance – colour change of less than 5 ΔE in 10 years. /  
UV-Beständigkeit – Farbveränderung von weniger als 5 ΔE in 10 Jahren. /  
Résistance aux UV – changement de couleur inférieur à 5 ΔE en 10 ans.

Noticeable traces after intensive use. / Fühlbare Spuren nach  
intensivem Gebrauch. / Traces visibles après une utilisation intensive.

Slight traces of heavy use, visible from a certain angle. /  
Leichte Gebrauchsspuren, die aus einem bestimmten Winkel sichtbar sind. /  
Légères traces d'utilisation intensive, visibles sous un certain angle.

Colour containing some recycled material. / Farbe mit einem Anteil an  
recycltem Material. / Couleur contenant des matériaux recyclés.

Designed for kitchen areas: Countertops with kitchen sink, wall  
cladding, tables, kitchen islands, shelves, racks. / Entworfen für den  
Küchenbereich: Küchenspültische, Wandverkleidungen, Tische,  
Kücheninseln, Regale, Ablagen. / Conçu pour les cuisines : Comptoirs  
d'évier, revêtements muraux, tables, îlots de cuisine, étagères, rayons.

Designed for bathrooms: Vanity tops, shelves, racks, shelving, wall  
cladding – an alternative to ceramic tiles. / Entworfen für Badezimmer:  
Waschtischplatten mit Becken, Ablagen, Regalen, Ablageflächen,  
Wandverkleidungen – eine Alternative zu Keramikfliesen. / Conçu  
pour les salles de bains : Comptoirs de lavabos avec vasques, étagères,  
supports, rayons, revêtements muraux – une alternative aux plaques  
de céramique.

For outdoor use: Facades, outdoor furnishings, benches, table tops,  
decorative elements. / Für die Verwendung im Freien: Fassaden,  
Außenmobiliar, Bänke, Tischplatten, dekorative Elemente. /  
Pour l'extérieur : Façades, équipement extérieur, bancs, plaques de  
table, éléments décoratifs.

The image features a background of marbled paper with a complex, organic pattern of swirling, vein-like shapes in shades of light grey, blue, and white. The pattern is dense and covers the entire surface. In the center of the image, the word "Natur" is printed in a bold, black, serif font. The text is centered both horizontally and vertically, standing out prominently against the intricate, light-colored background.

**Natur**

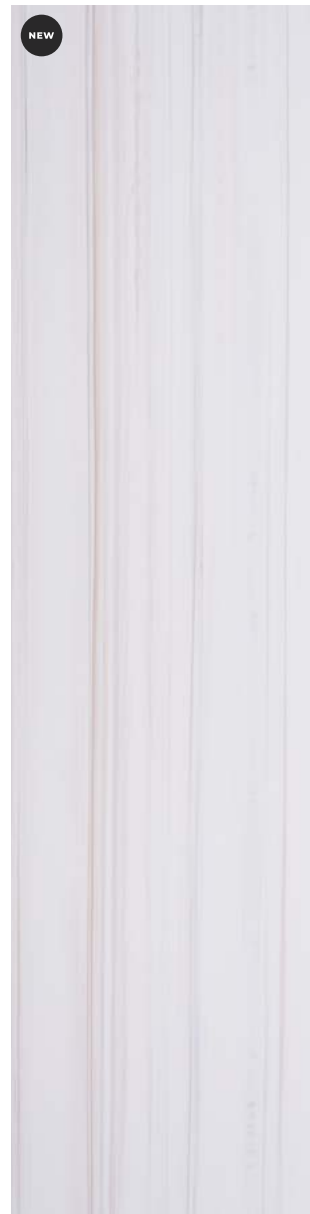

**MAGNESITE  
N 133**



 UV resistance – colour change of less than 5 ΔE in 10 years. /  
UV-Beständigkeit – Farbveränderung von weniger als 5 ΔE in 10 Jahren. /  
Résistance aux UV – changement de couleur inférieur à 5 ΔE en 10 ans.

 Slight traces of heavy use, visible from a certain angle. /  
Leichte Gebrauchsspuren, die aus einem bestimmten Winkel sichtbar sind. /  
Légères traces d'utilisation intensive, visibles sous un certain angle.

 Good thermoforming option, the material can be thermoformed up to the radius of curvature shown in the technical data sheet catalogue for Kerrock processing. It also allows you to create 3-dimensional shapes, although complex shapes can show slight discolouration on the curve. /  
Gute Tiefziehooption, das Material kann bis zu dem im technischen Datenblatt angegebenen Krümmungsradius tiefgezogen werden Katalog für die Verarbeitung von Kerrock-Material. Es ermöglicht Ihnen auch, 3-dimensionale Formen zu erstellen, obwohl bei komplexen Formen eine leichte Farbänderung am Radius auffallen kann. /  
Bonne option de thermoformage, le matériau peut être thermoformé jusqu'au rayon de courbure indiqué dans le catalogue technique de traitement des matériaux kerrock. Il vous permet également de créer des formes tridimensionnelles, bien que pour des formes complexes, une légère décoloration sur la courbe peut être visible.

**WHITE AGATE  
N 134**





**WHITE MAPLE  
N 546**



 Designed for kitchen areas: Countertops with kitchen sink, wall cladding, tables, kitchen islands, shelves, racks. / Entworfen für den Küchenbereich: Arbeitsplatten mit Spüle, Wandverkleidungen, Tische, Kücheninseln, Regale, Ablagen. / Conçu pour les cuisines : Comptoirs avec évier, revêtements muraux, tables, îlots de cuisine, étagères, supports.

 Designed for bathrooms: Vanity tops, shelves, racks, shelving, wall cladding – an alternative to ceramic tiles. / Entworfen für Badezimmer: Waschtischplatten mit Becken, Ablagen, Regalen, Ablageflächen, Wandverkleidungen – eine Alternative zu Keramikfliesen. / Conçu pour les salles de bains : Comptoirs de lavabos avec vasques, étagères, supports, rayons, revêtements muraux – une alternative aux plaques de céramique.

 For outdoor use: Facades, outdoor furnishings, benches, table tops, decorative elements. / Für die Verwendung im Freien: Fassaden, Außenmobiliar, Bänke, Tischplatten, dekorative Elemente. / Pour l'extérieur : Façades, équipement extérieur, bancs, plaques de table, éléments décoratifs.

 Translucency – semi-transparent colour when backlit. / Transluzenz – halbtransparente Farbe, wenn sie hinterleuchtet werden. / Translucidité – couleur semi-transparente lorsqu'elle est rétroéclairée.





TEAK WOOD  
N 548



 UV resistance – colour change of less than 5  $\Delta E$  in 10 years. /  
UV-Beständigkeit – Farbveränderung von weniger als 5  $\Delta E$  in 10 Jahren. /  
Résistance aux UV – changement de couleur inférieur à 5  $\Delta E$  en 10 ans.

 Noticeable traces after intensive use. / Fühlbare Spuren nach  
intensivem Gebrauch. / Traces visibles après une utilisation intensive.

 Minor traces after heavy use. / Leichte Gebrauchsspuren. /  
Traces mineures d'utilisation intensive.

 Slight traces of heavy use, visible from a certain angle. /  
Leichte Gebrauchsspuren, die aus einem bestimmten Winkel sichtbar sind. /  
Légères traces d'utilisation intensive, visibles sous un certain angle.



ICEBERG  
N 1258



 Designed for kitchen areas: Countertops with kitchen sink, wall cladding,  
tables, kitchen islands, shelves, racks. / Entworfen für den Küchenbereich:  
Arbeitsplatten mit Spüle, Wandverkleidungen, Tische, Kücheninseln,  
Regale, Ablagen. / Conçu pour les cuisines : Comptoirs avec évier,  
revêtements muraux, tables, îlots de cuisine, étagères, supports.

 Designed for bathrooms: Vanity tops, shelves, racks, shelving, wall  
cladding – an alternative to ceramic tiles. / Entworfen für Badezimmer:  
Waschtischplatten mit Becken, Ablagen, Regalen, Ablageflächen,  
Wandverkleidungen – eine Alternative zu Keramikfliesen. / Conçu  
pour les salles de bains : Comptoirs de lavabos avec vasques, étagères,  
supports, rayons, revêtements muraux – une alternative aux plaques  
de céramique.

 For outdoor use: Facades, outdoor furnishings, benches, table tops,  
decorative elements. / Für die Verwendung im Freien: Fassaden,  
Außenmobiliar, Bänke, Tischplatten, dekorative Elemente. /  
Pour l'extérieur : Façades, équipement extérieur, bancs, plaques de  
table, éléments décoratifs.



NEW



GRAYWACKE  
N 9259



- ~ Good thermoforming option, the material can be thermoformed up to the radius of curvature shown in the technical data sheet catalogue for Kerrock processing. It also allows you to create 3-dimensional shapes, although complex shapes can show slight discolouration on the curve. / Gute Tiefziehooption, das Material kann bis zu dem im technischen Datenblatt angegebenen Krümmungsradius tiefgezogen werden Katalog für die Verarbeitung von Kerrock-Material. Es ermöglicht Ihnen auch, 3-dimensionale Formen zu erstellen, obwohl bei komplexen Formen eine leichte Farbänderung am Radius auffallen kann. / Bonne option de thermoformage, le matériau peut être thermoformé jusqu'au rayon de courbure indiqué dans le catalogue technique de traitement des matériaux kerrock. Il vous permet également de créer des formes tridimensionnelles, bien que pour des formes complexes, une légère décoloration sur la courbe peut être visible.

- ~ Colour containing some recycled material. / Farbe mit einem Anteil an recyceltem Material. / Couleur contenant des matériaux recyclés.



The background of the page is a classic marbled paper pattern. It features a light, off-white or cream base color, overlaid with intricate, vertical, and slightly wavy bands of varying shades of grey, taupe, and muted green. The pattern has a soft, organic feel, reminiscent of traditional stone or liquid marbling techniques. The overall effect is elegant and textured.

**Marble**



**BUFFALO**  
**M 123**



 **UV resistance – colour change of less than 5 ΔE in 10 years. /**  
UV-Beständigkeit – Farbveränderung von weniger als 5 ΔE in 10 Jahren. /  
Résistance aux UV – changement de couleur inférieur à 5 ΔE en 10 ans.

 **Slight traces of heavy use, visible from a certain angle. /**  
Leichte Gebrauchsspuren, die aus einem bestimmten Winkel sichtbar sind. /  
Légères traces d'utilisation intensive, visibles sous un certain angle.

 **Good thermoforming option, the material can be thermoformed up to the radius of curvature shown in the technical data sheet catalogue for Kerrock processing. It also allows you to create 3-dimensional shapes, although complex shapes can show slight discolouration on the curve. /**  
Gute Tiefziehooption, das Material kann bis zu dem im technischen Datenblatt angegebenen Krümmungsradius tiefgezogen werden Katalog für die Verarbeitung von Kerrock-Material. Es ermöglicht Ihnen auch, 3-dimensionale Formen zu erstellen, obwohl bei komplexen Formen eine leichte Farbänderung am Radius auffallen kann. /  
Bonne option de thermoformage, le matériau peut être thermoformé jusqu'au rayon de courbure indiqué dans le catalogue technique de traitement des matériaux kerrock. Il vous permet également de créer des formes tridimensionnelles, bien que pour des formes complexes, une légère décoloration sur la courbe peut être visible.

**HOWLITE**  
**M 124**



**IVORY BROWN**  
**M 536**



 **Designed for kitchen areas: Countertops with kitchen sink, wall cladding, tables, kitchen islands, shelves, racks. /** Entworfen für den Küchenbereich: Arbeitsplatten mit Spüle, Wandverkleidungen, Tische, Kücheninseln, Regale, Ablagen. / **Conçu pour les cuisines :** Comptoirs avec évier, revêtements muraux, tables, îlots de cuisine, étagères, supports.

 **Designed for bathrooms: Vanity tops, shelves, racks, shelving, wall cladding – an alternative to ceramic tiles. /** Entworfen für Badezimmer: Waschtischplatten mit Becken, Ablagen, Regalen, Ablageflächen, Wandverkleidungen – eine Alternative zu Keramikfliesen. / **Conçu pour les salles de bains :** Comptoirs de lavabos avec vasques, étagères, supports, rayons, revêtements muraux – une alternative aux plaques de céramique.

 **For outdoor use: Facades, outdoor furnishings, benches, table tops, decorative elements. /** Für die Verwendung im Freien: Fassaden, Außenmobiliar, Bänke, Tischplatten, dekorative Elemente. / **Pour l'extérieur :** Façades, équipement extérieur, bancs, plaques de table, éléments décoratifs.



DIASPORE  
M 1060



☀️ UV resistance – colour change from 5  $\Delta E$  to 10  $\Delta E$  in 10 years. /  
UV-Beständigkeit – Farbveränderung von 5  $\Delta E$  auf 10  $\Delta E$  in 10 Jahren. /  
Résistance aux UV – Changement de couleur de 5  $\Delta E$  à 10  $\Delta E$  en 10 ans.

☀️ UV resistance – colour change of less than 5  $\Delta E$  in 10 years. /  
UV-Beständigkeit – Farbveränderung von weniger als 5  $\Delta E$  in 10 Jahren. /  
Résistance aux UV – changement de couleur inférieur à 5  $\Delta E$  en 10 ans.



ALABASTER  
M 1156



✍️ Noticeable traces after intensive use. / Fühlbare Spuren nach intensivem Gebrauch. / Traces visibles après une utilisation intensive.

✍️ Minor traces after heavy use. / Leichte Gebrauchsspuren. / Traces mineures d'utilisation intensive.

✍️ Slight traces of heavy use, visible from a certain angle. / Leichte Gebrauchsspuren, die aus einem bestimmten Winkel sichtbar sind. / Légères traces d'utilisation intensive, visibles sous un certain angle.



BARITE  
M 5079



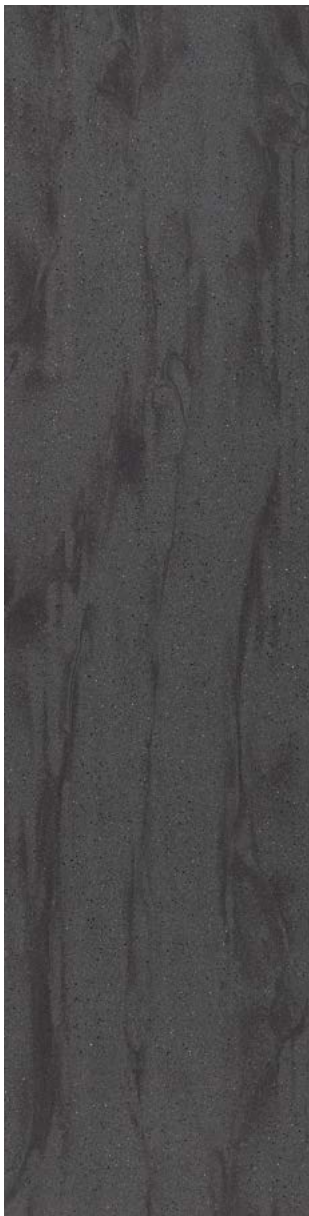

GABBRO  
M 9078



PYROXENE  
M 9197



PANTHEON  
M 9202



~ Good thermoforming option, the material can be thermoformed up to the radius of curvature shown in the technical data sheet catalogue for Kerrock processing. It also allows you to create 3-dimensional shapes, although complex shapes can show slight discolouration on the curve. / Gute Tiefziehooption, das Material kann bis zu dem im technischen Datenblatt angegebenen Krümmungsradius tiefgezogen werden Katalog für die Verarbeitung von Kerrock-Material. Es ermöglicht Ihnen auch, 3-dimensionale Formen zu erstellen, obwohl bei komplexen Formen eine leichte Farbänderung am Radius auffallen kann. / Bonne option de thermoformage, le matériau peut être thermoformé jusqu'au rayon de courbure indiqué dans le catalogue technique de traitement des matériaux kerrock. Il vous permet également de créer des formes tridimensionnelles, bien que pour des formes complexes, une légère décoloration sur la courbe peut être visible.

 Designed for kitchen areas: Countertops with kitchen sink, wall cladding, tables, kitchen islands, shelves, racks. / Entworfen für den Küchenbereich: Arbeitsplatten mit Spüle, Wandverkleidungen, Tische, Kücheninseln, Regale, Ablagen. / Conçu pour les cuisines : Comptoirs avec évier, revêtements muraux, tables, îlots de cuisine, étagères, supports.

 Designed for bathrooms: Vanity tops, shelves, racks, shelving, wall cladding – an alternative to ceramic tiles. / Entworfen für Badezimmer: Waschtischplatten mit Becken, Ablagen, Regalen, Ablageflächen, Wandverkleidungen – eine Alternative zu Keramikfliesen. / Conçu pour les salles de bains : Comptoirs de lavabos avec vasques, étagères, supports, rayons, revêtements muraux – une alternative aux plaques de céramique.

 For outdoor use: Facades, outdoor furnishings, benches, table tops, decorative elements. / Für die Verwendung im Freien: Fassaden, Außenmobiliar, Bänke, Tischplatten, dekorative Elemente. / Pour l'extérieur : Façades, équipement extérieur, bancs, plaques de table, éléments décoratifs.

# MIDNIGHT BLACK



NERO  
MB 990

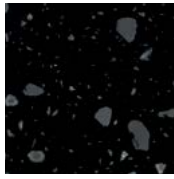

LAVASTONE  
MB 9955



# LUMINO

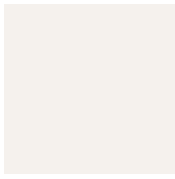

WHITE  
II



# LUMINACO



STRONTIANITE  
8101

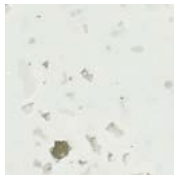

LUXITE  
8102

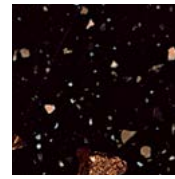

OPAL BROWN  
8901



94

The original blend of Terrazzo effect and translucent particles. / Die originelle Mischung aus Terrazzo-Effekt und lichtdurchlässigen Partikeln. / Le mélange original de l'effet Terrazzo et de particules translucides.

 UV resistance – colour change from 5 ΔE to 10 ΔE in 10 years. / UV-Beständigkeit – Farbveränderung von 5 ΔE auf 10 ΔE in 10 Jahren. / Résistance aux UV – Changement de couleur de 5 ΔE à 10 ΔE en 10 ans.

 Noticeable traces after intensive use. / Fühlbare Spuren nach intensivem Gebrauch. / Traces visibles après une utilisation intensive.

 Minor traces after heavy use. / Leichte Gebrauchsspuren. / Traces mineures d'utilisation intensive.

 Slight traces of heavy use, visible from a certain angle. / Leichte Gebrauchsspuren, die aus einem bestimmten Winkel sichtbar sind. / Légères traces d'utilisation intensive, visibles sous un certain angle.

 Designed for kitchen areas: Countertops with kitchen sink, wall cladding, tables, kitchen islands, shelves, racks. / Entworfen für den Küchenbereich: Arbeitsplatten mit Spüle, Wandverkleidungen, Tische, Kücheninseln, Regale, Ablagen. / Conçu pour les cuisines : Comptoirs avec évier, revêtements muraux, tables, îlots de cuisine, étagères, supports.

 Designed for bathrooms: Vanity tops, shelves, racks, shelving, wall cladding – an alternative to ceramic tiles. / Entworfen für Badezimmer: Waschtischplatten mit Becken, Ablagen, Regalen, Ablageflächen, Wandverkleidungen – eine Alternative zu Keramikfliesen. / Conçu pour les salles de bains : Comptoirs de lavabos avec vasques, étagères, supports, rayons, revêtements muraux – une alternative aux plaques de céramique.

 For outdoor use: Facades, outdoor furnishings, benches, table tops, decorative elements. / Für die Verwendung im Freien: Fassaden, Außenmobiliar, Bänke, Tischplatten, dekorative Elemente. / Pour l'extérieur : Façades, équipement extérieur, bancs, plaques de table, éléments décoratifs.

# METALIC

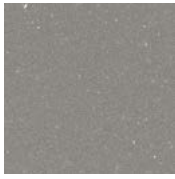

PLATINUM  
1071\*

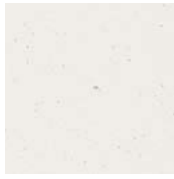

WHITE GLITTER  
1194\*



GRAPHITE  
9070\*

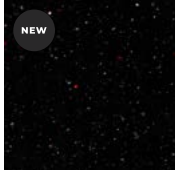

BLACK  
SPECULARITE  
9170\*



\* With glitter / Mit Glitzer / Avec des paillettes

# KERROCK MF

MED CERTIFICATE



MF 178



# EASY SHAPING





ES 112



 UV resistance – colour change of less than 5 ΔE in 10 years. /  
UV-Beständigkeit – Farbveränderung von weniger als 5 ΔE in 10 Jahren. /  
Résistance aux UV – changement de couleur inférieur à 5 ΔE en 10 ans.

 Translucency – transparent colour when backlit. /  
Transluzenz – transparente Farbe, wenn sie von hinten beleuchtet wird. /  
Translucidité – couleur translucide lorsqu'elle est rétroéclairée.

 High thermoformability, allowing the creation of 3-dimensional shapes. Extreme shapes can be made, can slight discolouration on the curve. / Hohe Thermoformbarkeit, die die Herstellung von 3-dimensionalen Formen ermöglicht. Extreme Formen können gemacht werden, können eine leichte Farbänderung auf der Kurve auffallen kann. / Grande possibilité de thermoformage, permettant la création de formes tridimensionnelles. Des formes extrêmes peuvent être créées, une légère décoloration sur la courbe peut être visible.

 Good thermoforming option, the material can be thermoformed up to the radius of curvature shown in the technical data sheet catalogue for Kerrock processing. It also allows you to create 3-dimensional shapes, although complex shapes can show slight discolouration on the curve. / Gute Tiefziehooption, das Material kann bis zu dem im technischen Datenblatt angegebenen Krümmungsradius tiefgezogen werden Katalog für die Verarbeitung von Kerrock-Material. Es ermöglicht Ihnen auch, 3-dimensionale Formen zu erstellen, obwohl bei komplexen Formen eine leichte Farbänderung am Radius auffallen kann. / Bonne option de thermoformage, le matériau peut être thermoformé jusqu'au rayon de courbure indiqué dans le catalogue technique de traitement des matériaux kerrock. Il vous permet également de créer des formes tridimensionnelles, bien que pour des formes complexes, une légère décoloration sur la courbe peut être visible.





# LEGEND. LEGENDE. LÉGENDE.



UV resistance – colour change 5 ΔE to 10 ΔE in 10 years. / UV-Beständigkeit – Farbveränderung 5 ΔE bis 10 ΔE in 10 Jahren. / Résistance aux UV – Changement de couleur de 5 ΔE à 10 ΔE en 10 ans.



UV resistance – colour change of less than 5 ΔE in 10 years. / UV-Beständigkeit – Farbveränderung um weniger als 5 ΔE in 10 Jahren. / Résistance aux UV – changement de couleur de moins de 5 ΔE en 10 ans.



Designed for kitchen areas: Countertops with kitchen sink, wall coverings, tables, kitchen islands, shelves, racks. / Entworfen für den Küchenbereich: Arbeitsflächen mit Küchenspüle, Wandverkleidungen, Tische, Kücheninseln, Regale, Ablagen. / Conçu pour les cuisines : Compteurs avec évier de cuisine, revêtements muraux, tables, îlots de cuisine, étagères, supports.



Designed for bathrooms: Vanity tops, shelves, racks, shelving, wall cladding – an alternative to ceramic tiles. / Entworfen für Badezimmer: Waschraumtische mit Becken, Regalen und Ablagen, Ablageflächen, Wandverkleidungen – eine Alternative zu Keramikfliesen. / Conçu pour les salles de bains : Comptoirs de salle de bains avec vasques, étagères, supports, rayons, revêtements muraux – alternative aux plaques de céramique.



For outdoor use: Facades, outdoor furnishings, benches, table tops, decorative elements. / Für die Verwendung im Freien: Fassaden, Möbel für den Außenbereich, Bänke, Tischplatten, dekorative Elemente. / Pour l'extérieur : Façade, équipement extérieur, bancs, plaques de table, éléments décoratifs.



Translucency – semi-transparent colour when backlit. / Transluzenz – halbtransparente Farbe, wenn sie hinterleuchtet werden. / Translucidité – couleur semi-transparente lorsqu'elle est rétroéclairée.



Translucency – transparent colour when backlit. / Transluzenz – transparente Farbe, wenn sie beleuchtet wird von hinten. / Translucidité – couleur translucide lorsqu'elle est rétro-éclairée.



Noticeable traces after intensive use. / Fühlbare Spuren nach intensivem Gebrauch. / Traces visibles après une utilisation intensive.



Minor traces after heavy use. / Leichte Gebrauchsspuren. / Traces mineures d'utilisation intensive.



Slight traces of intensive use, visible from a certain angle. / Leichte Spuren von intensiver Nutzung, aus einem bestimmten Winkel sichtbar. / Légères traces d'utilisation intensive, visibles sous un certain angle.



Good thermoforming option, the material can be thermoformed up to the radius of curvature shown in the technical data sheet catalogue for Kerrock processing. It also allows you to create 3-dimensional shapes, although complex shapes can show slight discolouration on the curve. / Gute Tiefziehooption, das Material kann bis zu dem im technischen Datenblatt angegebenen Krümmungsradius tiefgezogen werden Katalog für die Verarbeitung von Kerrock-Material. Es ermöglicht Ihnen auch, 3-dimensionale Formen zu erstellen, obwohl bei komplexen Formen eine leichte Farbänderung am Radius auffallen kann. /

Bonne option de thermoformage, le matériau peut être thermoformé jusqu'au rayon de courbure indiqué dans le catalogue technique de traitement des matériaux kerrock. Il vous permet également de créer des formes tridimensionnelles, bien que pour des formes complexes, une légère décoloration sur la courbe peut être visible.



Great potential for thermoforming, which allows you to create 3-dimensional shapes. Extreme shapes can be made, can slight discolouration on the curve. / Großes Potenzial für die Thermoformung, die ermöglicht, 3-dimensionale Formen zu erstellen. Extreme Formen können gemacht werden, können eine leichte Farbänderung auf der Kurve auffallen kann. / Grande possibilité de thermoformage, qui vous permet de créer des formes tridimensionnelles. Des formes extrêmes peuvent être créées, une légère décoloration sur la courbe peut être visible.



Colour containing some recycled material. / Farbe mit einem Anteil an recyceltem Material. / Couleur contenant des matériaux recyclés.



**The greatness  
of design lies in  
the smallest of  
detail.**

DIE GRÖßE DES DESIGNS LIEGT IM  
KLEINSTEN DETAIL.

LA GRANDEUR DU DESIGN RÉSIDE DANS  
LE PLUS PETIT DÉTAIL.

**Kerrock  
products  
Kerrock  
Produkte  
Produits  
Kerrock**



# Washbasins

Good morning. Good day and good night. Kerrock washbasins greet you every time with their usability, resistance, easy cleaning and timeless design.

# Waschbecken

Guten Morgen. Guten Tag und gute Nacht. Die Waschbecken aus Kerrock überzeugen durch ihre Benutzerfreundlichkeit, ihre Widerstandsfähigkeit, ihre einfache Reinigung und ihr zeitloses Design.

# Vasques

Bonjour. Bonne journée et bonne nuit. Les lavabos Kerrock vous séduisent à chaque fois par leur facilité d'utilisation, leur résistance, leur facilité de nettoyage et leur design intemporel.

There may be variations in shade between bowls and sheets of the same colour. Actual dimensions may differ from those shown (from the plan).

Zwischen Becken und Platten der gleichen Farbe kann es zu Farbabweichungen kommen. Die tatsächlichen Abmessungen können von den gezeigten (aus dem Plan) abweichen.

Il peut y avoir des variations de teinte entre les vasques et les panneaux d'une même couleur. Les dimensions réelles peuvent différer de celles indiquées (sur le plan).



ON – Bowl on the counter / Becken auf der Theke / Vasque à poser



IN – Bowl built into the counter / Becken in die Arbeitsplatte eingebaut / Vasque à intégrer



UN – Bowl built under the counter / Becken unter der Arbeitsplatte eingebaut / Vasque sous plan

# WASHBASINS. WASCHBECKEN. VASQUES.

**JANA-UN**   
 ø 242 mm / 97 mm / ø 46 mm

- ①
- ②
- ③
- ⑧
- ⑨

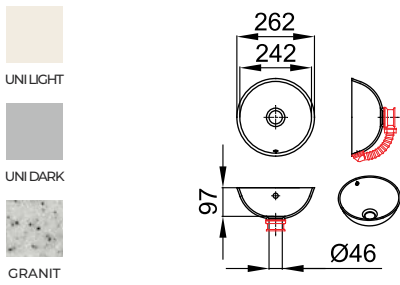

**KERI-UN**   
 ø 343 mm / 114 mm / ø 46 mm

- ①
- ②
- ③
- ⑧
- ⑨

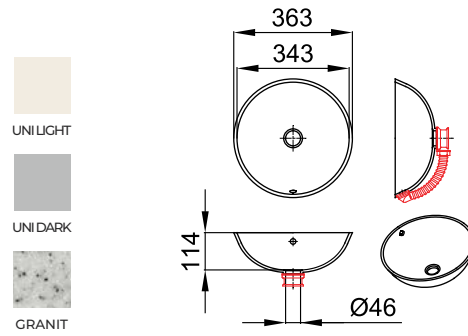

**META-UN**   
 ø 390 mm / 155 mm / ø 46 mm

- ①
- ②
- ③
- ⑧
- ⑨

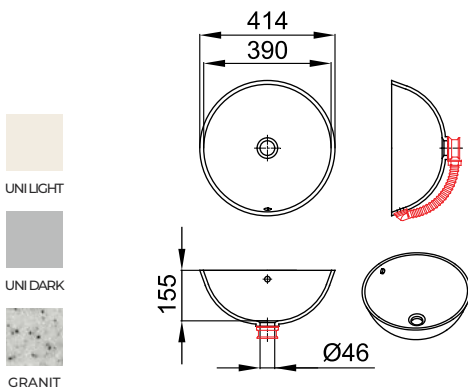

**RONDO-UN**   
 ø 432 mm / 120 mm / ø 46 mm

- ①
- ②
- ③
- ⑧
- ⑨

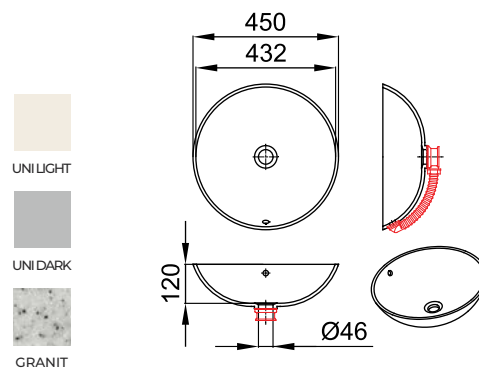

# WASHBASINS. WASCHBECKEN. VASQUES.

## TISA-UN

418 mm / 332 mm / 100 mm / ø 46 mm

- ①
- ②
- ③
- ⑧
- ⑨

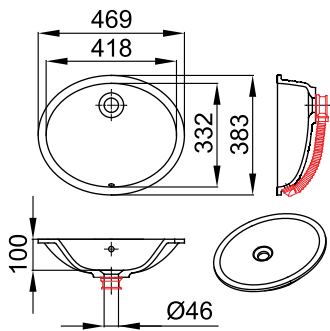

- 108
- 129

## ANA-UN

405 mm / 274 mm / 102 mm / ø 46 mm

- ①
- ②
- ③
- ⑧
- ⑨

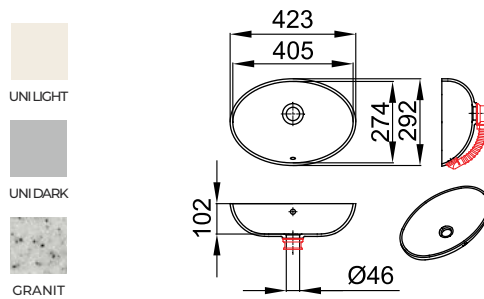

- UNILIGHT
- UNIDARK
- GRANIT

## BLANCA-UN

404 mm / 323 mm / 110 mm / ø 46 mm

- ①
- ②
- ③
- ⑧
- ⑨

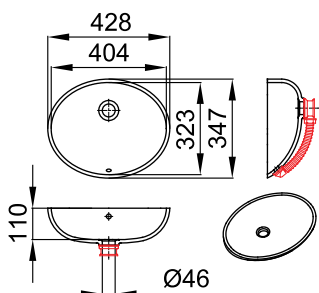

- UNILIGHT
- UNIDARK
- GRANIT



# WASHBASINS. WASCHBECKEN. VASQUES.

## MAJA-UN

480 mm / 351 mm / 125 mm / ø 46 mm

- ①
- ②
- ③
- ⑧
- ⑨

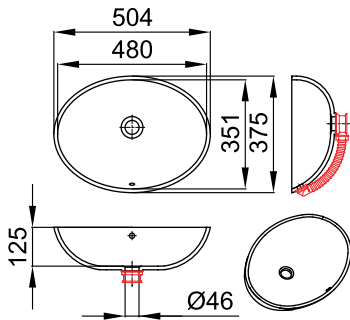

## AJDA-UN

496 mm / 361 mm / 120 mm / ø 46 mm

- ①
- ②
- ③
- ⑧
- ⑨

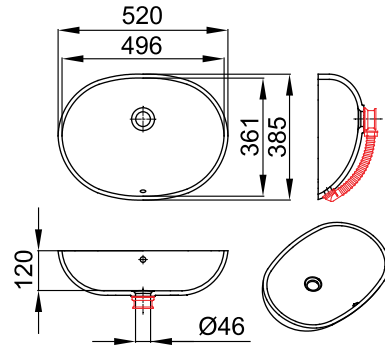

104

## IVA-UN

503 mm / 390 mm / 124 mm / ø 46 mm

- ①
- ②
- ③
- ⑧
- ⑨

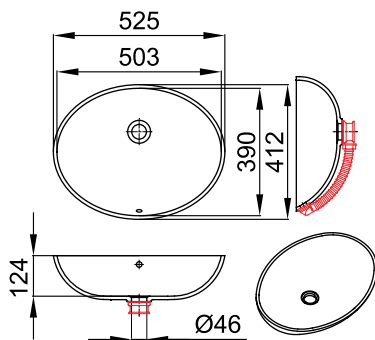

## BEA-UN

720 mm / 377 mm / 165 mm / ø 46 mm

- ①
- ②
- ③
- ⑧
- ⑨

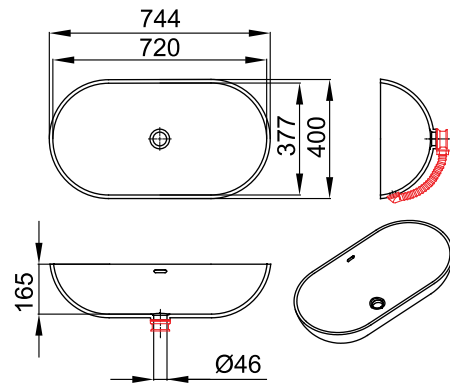



# WASHBASINS. WASCHBECKEN. VASQUES.

## INA 400-UN

400 mm / 300 mm / 110 mm /  $\varnothing$  46 mm

- ①
- ②
- ③
- ⑧
- ⑨



- 100
- 108
- 129
- 503
- 901

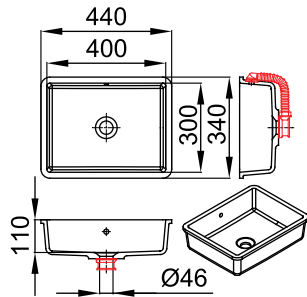

## INA 500-UN

500 mm / 300 mm / 110 mm /  $\varnothing$  46 mm

- ①
- ②
- ③
- ⑧
- ⑨



- 100
- 108
- 129
- 503
- 901

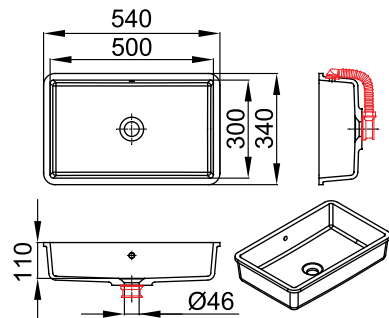

## INA 600-UN

600 mm / 300 mm / 110 mm /  $\varnothing$  46 mm

- ①
- ②
- ③
- ⑧
- ⑨



- 100
- 108
- 129
- 503
- 901

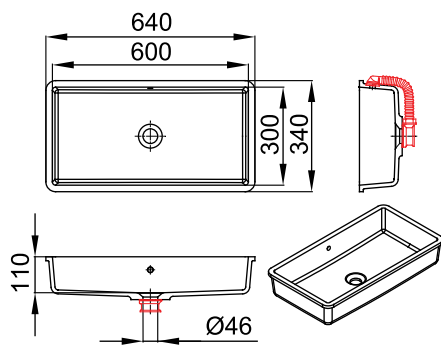

## INA 700-UN

700 mm / 300 mm / 110 mm /  $\varnothing$  46 mm

- ①
- ②
- ③
- ⑧
- ⑨



- 100
- 108
- 129
- 503
- 901

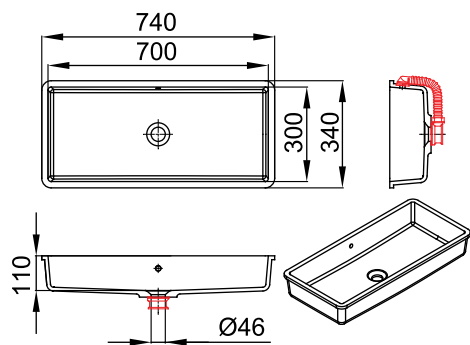

# WASHBASINS. WASCHBECKEN. VASQUES.

## BRINA-UN

450 mm / 300 mm / 116 mm /  $\varnothing$  46 mm

- ①
- ②
- ③
- ⑧
- ⑨

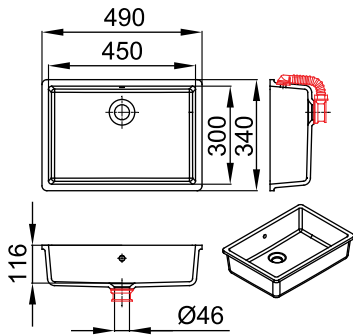

## CHERI-UN

500 mm / 350 mm / 116 mm /  $\varnothing$  46 mm

- ①
- ②
- ③
- ⑧
- ⑨

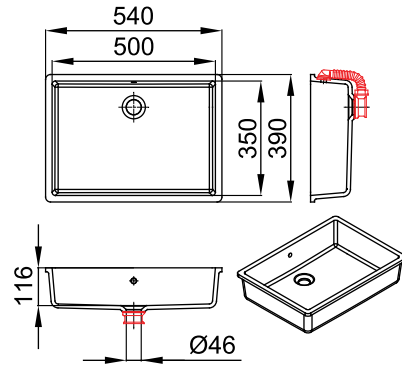

## LORA-UN

580 mm / 370 mm / 116 mm /  $\varnothing$  46 mm

- ①
- ②
- ③
- ⑧
- ⑨

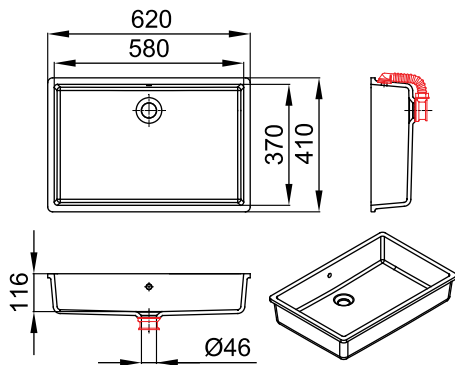

## KELI-UN

580 mm / 370 mm / 120 mm /  $\varnothing$  46 mm

- ①
- ②
- ③
- ⑧
- ⑨

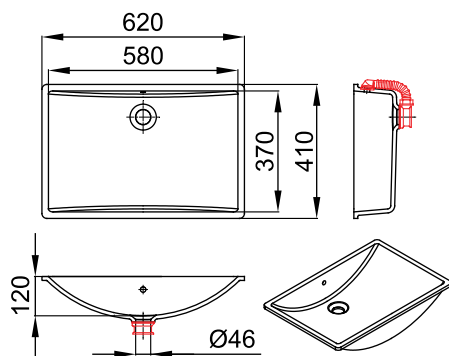

# WASHBASINS. WASCHBECKEN. VASQUES.

## WASHBASIN. WASCHBECKEN. VASQUE.

## SIPHONES. SIPHONS. SIPHONS.

<b>JANA-UN</b>	ø 242 mm / 97 mm / ø 46 mm	1 2 3 8 9
<b>KERI-UN</b>	ø 343 mm / 114 mm / ø 46 mm	1 2 3 8 9
<b>META-UN</b>	ø 390 mm / 155 mm / ø 46 mm	1 2 3 8 9
<b>RONDO-UN</b>	ø 432 mm / 120 mm / ø 46 mm	1 2 3 8 9
<b>TISA-UN</b>	418 mm / 332 mm / 100 mm / ø 46 mm	1 2 3 8 9
<b>ANA-UN</b>	405 mm / 274 mm / 102 mm / ø 46 mm	1 2 3 8 9
<b>BLANCA-UN</b>	404 mm / 323 mm / 110 mm / ø 46 mm	1 2 3 8 9
<b>MAJA-UN</b>	480 mm / 351 mm / 125 mm / ø 46 mm	1 2 3 8 9
<b>AJDA-UN</b>	496 mm / 361 mm / 120 mm / ø 46 mm	1 2 3 8 9
<b>IVA-UN</b>	503 mm / 390 mm / 124 mm / ø 46 mm	1 2 3 8 9
<b>BEA-UN</b>	720 mm / 377 mm / 165 mm / ø 46 mm	1 2 3 8 9
<b>INA 400-UN</b>	400 mm / 300 mm / 110 mm / ø 46 mm	1 2 3 8 9
<b>INA 500-UN</b>	500 mm / 300 mm / 110 mm / ø 46 mm	1 2 3 8 9
<b>INA 600-UN</b>	600 mm / 300 mm / 110 mm / ø 46 mm	1 2 3 8 9
<b>INA 700-UN</b>	700 mm / 300 mm / 110 mm / ø 46 mm	1 2 3 8 9
<b>BRINA-UN</b>	450 mm / 300 mm / 116 mm / ø 46 mm	1 2 3 8 9
<b>CHERI-UN</b>	500 mm / 350 mm / 116 mm / ø 46 mm	1 2 3 8 9
<b>LORA-UN</b>	580 mm / 370 mm / 116 mm / ø 46 mm	1 2 3 8 9
<b>KELI-UN</b>	580 mm / 370 mm / 120 mm / ø 46 mm	1 2 3 8 9

107



1 SIPHON FI 46 FOR BOWL



2 CLICK-CLACK/FOR BOWL WITH O/CR/FI 46



3 CLICK-CL./BOWL WITH O/KERR108/FI 46



8 SIPHON PVC SPACE SAVING FOR BOWL PVC/FI 46



9 SIPHON FOR BOWL/CR/FI 46

# WASHBASINS. WASCHBECKEN. VASQUES.

## BRINA V-UN

450 mm / 300 mm / 116 mm /  $\varnothing$  46 mm

- ①
- ⑦
- ⑧
- ⑨

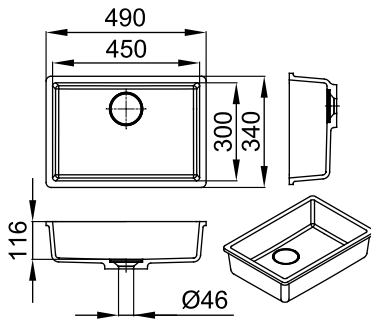

- 108
- 129

## CHERI V-UN

500 mm / 350 mm / 116 mm /  $\varnothing$  46 mm

- ①
- ⑦
- ⑧
- ⑨

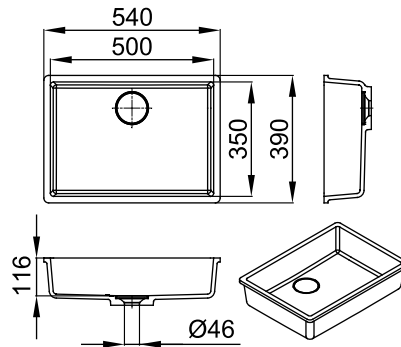

- 108
- 129

108

## LORA V-UN

580 mm / 370 mm / 116 mm /  $\varnothing$  46 mm

- ①
- ⑦
- ⑧
- ⑨

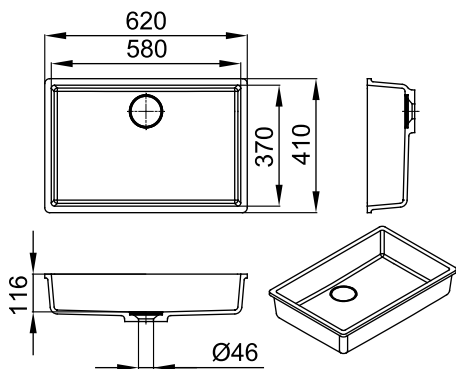

- 108
- 129

## VITA V-UN

460 mm / 370 mm / 163 mm /  $\varnothing$  46 mm

- ①
- ⑦
- ⑧
- ⑨

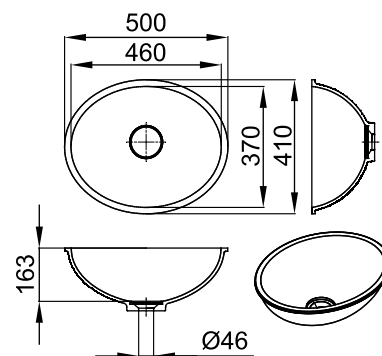

- 108
- 129

# WASHBASINS. WASCHBECKEN. VASQUES.

## RUBY V-UN

531 mm / 301 mm / 84 mm / ø 46 mm

- ①
- ⑦
- ⑧
- ⑨

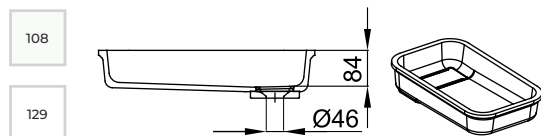
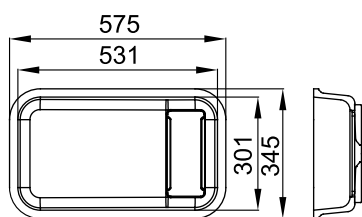

### WASHBASIN. WASCHBECKEN. VASQUE.

### SIPHONES. SIPHONS. SIPHONS.

<b>BRINA V-UN</b>	450 mm / 300 mm / 116 mm / ø 46 mm
<b>CHERI V-UN</b>	500 mm / 350 mm / 116 mm / ø 46 mm
<b>LORA V-UN</b>	580 mm / 370 mm / 116 mm / ø 46 mm
<b>VITA V-UN</b>	460 mm / 370 mm / 163 mm / ø 46 mm
<b>RUBY V-UN</b>	531 mm / 301 mm / 84 mm / ø 46 mm

- ① ⑦ ⑧ ⑨
- ① ⑦ ⑧ ⑨
- ① ⑦ ⑧ ⑨
- ① ⑦ ⑧ ⑨
- ① ⑦ ⑧ ⑨



① SIPHON FI 46 FOR BOWL



⑦ DRAIN KIARA FOR BOWL WITHOUT O/CR/FI 46



⑧ SIPHON PVC SPACE SAVING FOR BOWL PVC/FI 46



⑨ SIPHON FOR BOWL/CR/FI 45

# WASHBASINS. WASCHBECKEN. VASQUES.

SOFT 380 V-ON   
 ø 366 mm / 109 mm / ø 46 mm

- 4\*
- 8
- 9

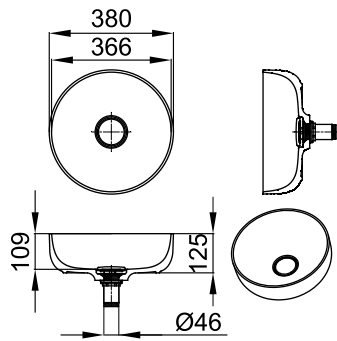

- 108
- 129

SOFT 380 V-IN   
 ø 366 mm / 109 mm / ø 46 mm

- 4\*
- 8
- 9

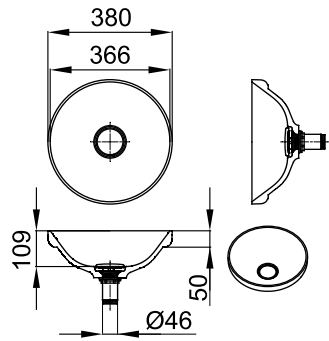

- 108
- 129

110

SOFT 380 V-UN   
 ø 366 mm / 109 mm / ø 46 mm

- 4\*
- 8
- 9

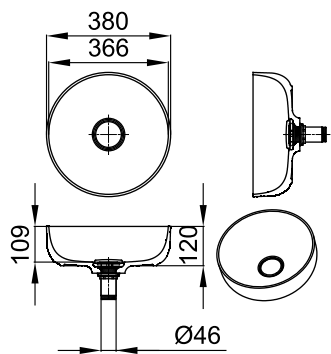

- 108
- 129



# WASHBASINS. WASCHBECKEN. VASQUES.

## SOFT 550 V-ON

536 mm / 346 mm / 109 mm / ø 46 mm

- 4\*
- 8
- 9

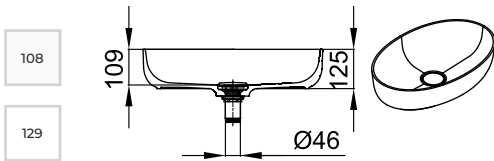
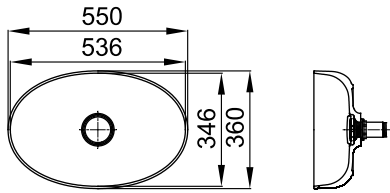

## SOFT 550 V-IN

536 mm / 345 mm / 109 mm / ø 46 mm

- 4\*
- 8
- 9

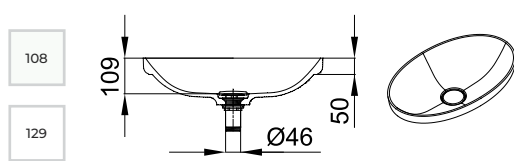
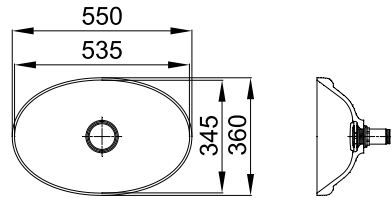

## SOFT 550 V-UN

536 mm / 346 mm / 109 mm / ø 46 mm

- 4\*
- 8
- 9

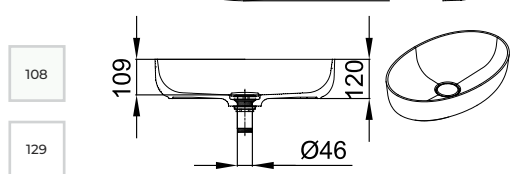
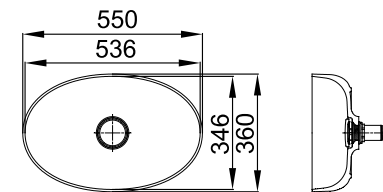

# WASHBASINS. WASCHBECKEN. VASQUES.

GLORIA 580 V-IN   
547 mm / 367 mm / 100 mm / ø 46 mm

- ④\*
- ⑧
- ⑨

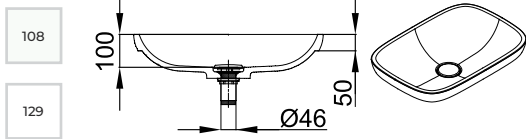
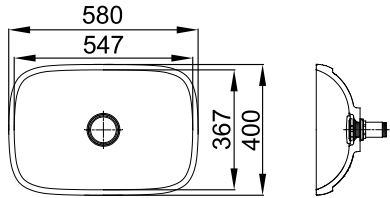

GLORIA 580 V-UN   
547 mm / 367 mm / 100 mm / ø 46 mm

- ④\*
- ⑧
- ⑨

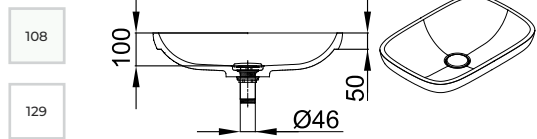
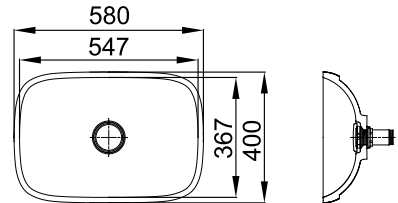

GLORIA 880 V-IN   
848 mm / 368 mm / 100 mm / ø 46 mm

- ④\*
- ⑧
- ⑨

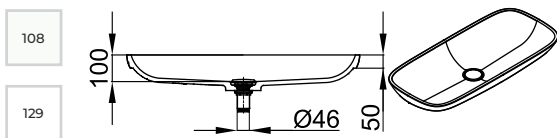
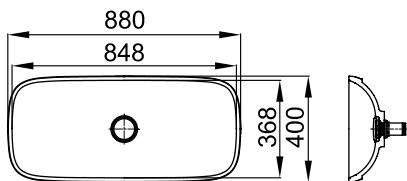

GLORIA 880 V-UN   
848 mm / 368 mm / 100 mm / ø 46 mm

- ④\*
- ⑧
- ⑨

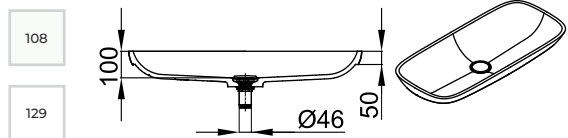
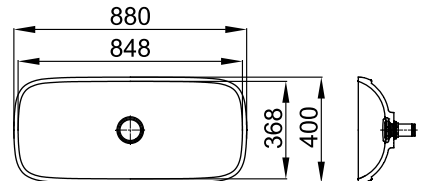



# WASHBASINS. WASCHBECKEN. VASQUES.

## LUX 380 V-ON

377 mm / 377 mm / 109 mm /  $\varnothing$  46 mm

- ④\*
- ⑧
- ⑨

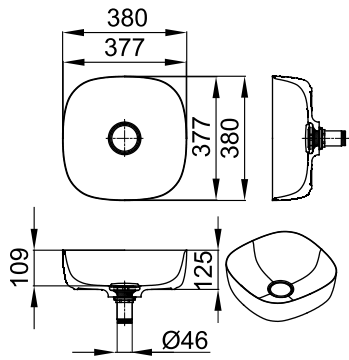

- 108
- 129

## LUX 380 V-IN

378 mm / 378 mm / 109 mm /  $\varnothing$  46 mm

- ④\*
- ⑧
- ⑨

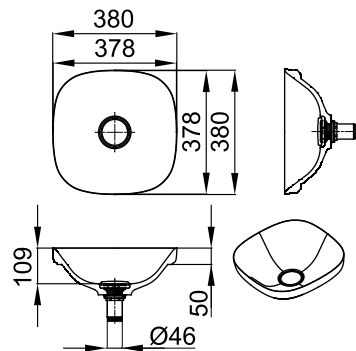

- 108
- 129

## LUX 380 V-UN

368 mm / 368 mm / 109 mm /  $\varnothing$ 46 mm

- ④\*
- ⑧
- ⑨

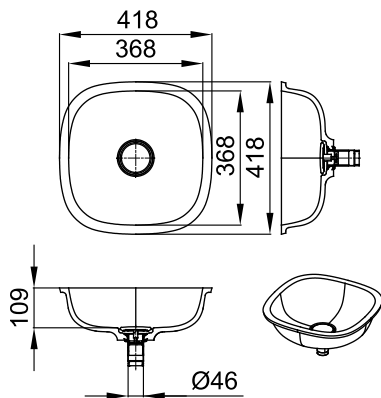

- 108
- 129

## LUX 500 V-ON

497 mm / 357 mm / 109 mm /  $\varnothing$  46 mm

- ④\*
- ⑧
- ⑨

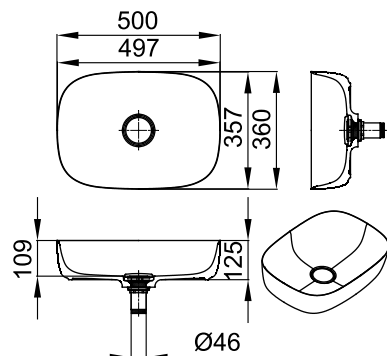

- 108
- 129

# WASHBASINS. WASCHBECKEN. VASQUES.

## LUX 500 V-IN

498 mm / 358 mm / 109 mm /  $\varnothing$  46 mm

- 4\*
- 8
- 9

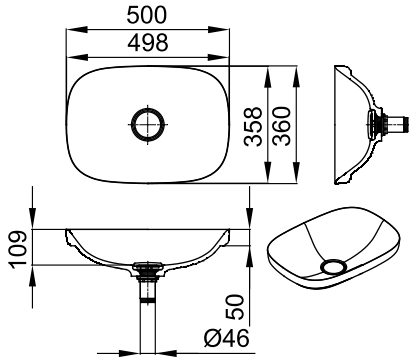

- 108
- 129

## LUX 500 V-UN

487 mm / 347 mm / 109 mm /  $\varnothing$ 46 mm

- 4\*
- 8
- 9

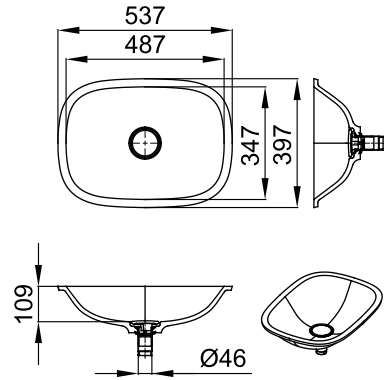

- 108
- 129

114

## DEMI V-ON

544 mm / 356 mm / 130 mm /  $\varnothing$  46 mm

- 4\*
- 8
- 9

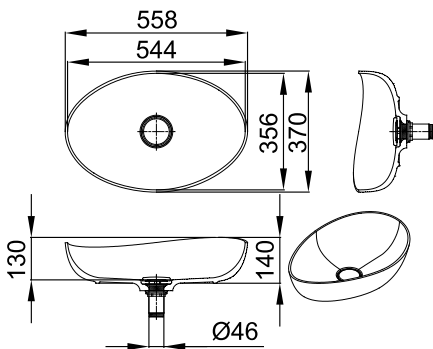

- 108
- 129

## ODA V-ON

550 mm / 425 mm / 109 mm /  $\varnothing$  46 mm

- 4\*
- 8
- 9

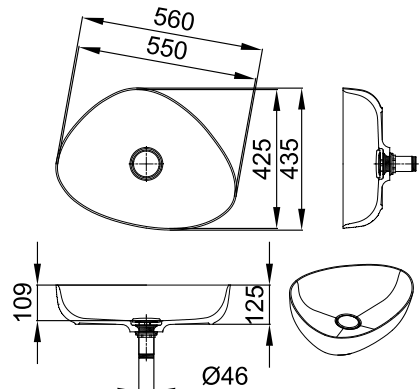

- 108
- 129

# WASHBASINS. WASCHBECKEN. VASQUES.

## ARIANA 370 V-ON

354 mm / 354 mm / 119 mm / ø 46 mm

- ④\*
- ⑧
- ⑨

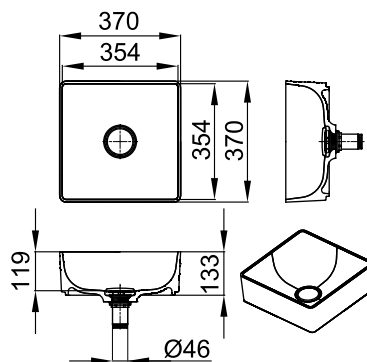

- 108
- 129

## ARIANA 370 V-UN

354 mm / 354 mm / 119 mm / ø46 mm

- ④\*
- ⑧
- ⑨

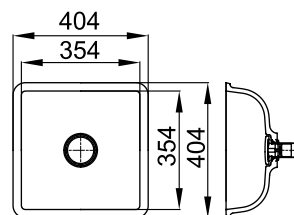

- 108
- 129

## ARIANA 550 V-ON

534 mm / 354 mm / 119 mm / ø 46 mm

- ④\*
- ⑧
- ⑨

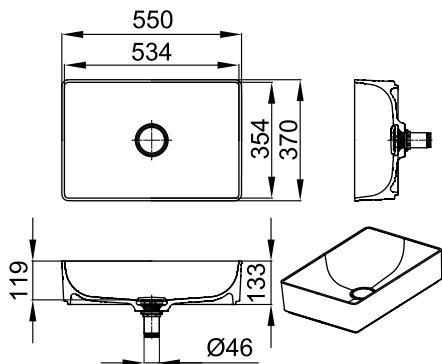

- 108
- 129

## ARIANA 550 V-UN

534 mm / 354 mm / 119 mm / ø46 mm

- ④\*
- ⑧
- ⑨

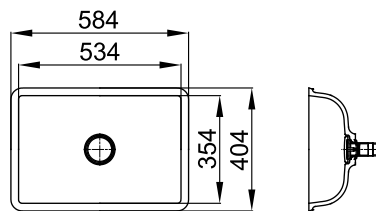

- 108
- 129

# WASHBASINS. WASCHBECKEN. VASQUES.

KIARA 450-UN   
450 mm / 300 mm / 74 mm /  $\varnothing$ 46 mm

- 7\*\*
- 8
- 9

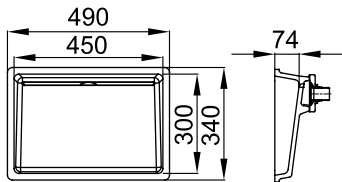

- 108
- 129

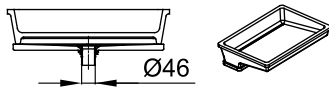

KIARA 450 V-UN   
450 mm / 300 mm / 74 mm /  $\varnothing$ 46 mm

- 1
- 7
- 8
- 9

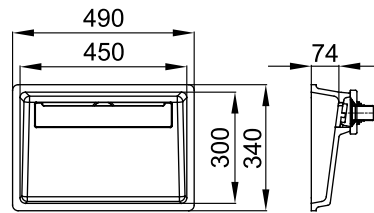

- 108
- 129

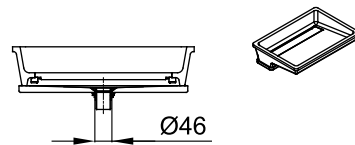

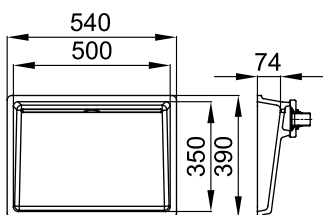

KIARA 500-UN   
500 mm / 350 mm / 74 mm /  $\varnothing$ 46 mm

- 7\*\*
- 8
- 9

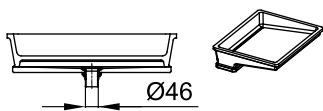

- 108
- 129



KIARA 500 V-UN   
500 mm / 350 mm / 74 mm /  $\varnothing$ 46 mm

- 1
- 7
- 8
- 9

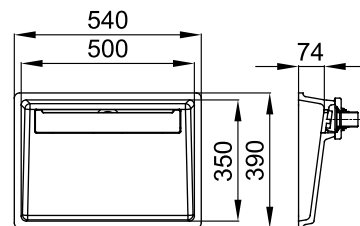

- 108
- 129

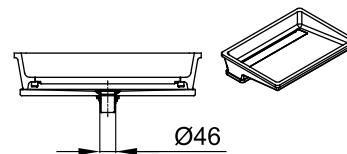

# WASHBASINS. WASCHBECKEN. VASQUES.

KIARA 700-UN   
700 mm/ 350 mm/ 74 mm / ø46 mm

- 7\*\*
- 8
- 9

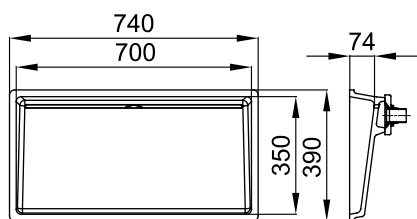

108

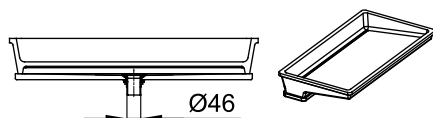

129

KIARA 700 V-UN   
700 mm/ 350 mm/ 74 mm / ø46 mm

- 1
- 7
- 8
- 9

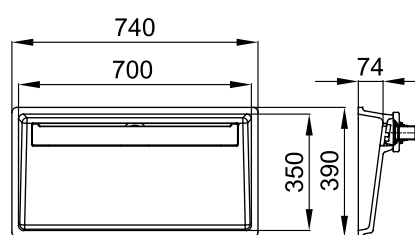

108

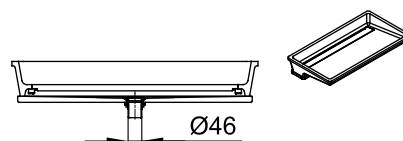

129



# VANITY TOPS. WASCHBECKEN. LAVABOS.

## ASTORIA 610-V

610 mm / 485 mm / 110 mm / ø46 mm

- ④\*
- ⑧
- ⑨

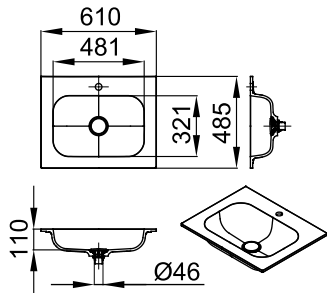

- 108
- 129

## ASTORIA 710-V

710 mm / 485 mm / 110 mm / ø46 mm

- ④\*
- ⑧
- ⑨

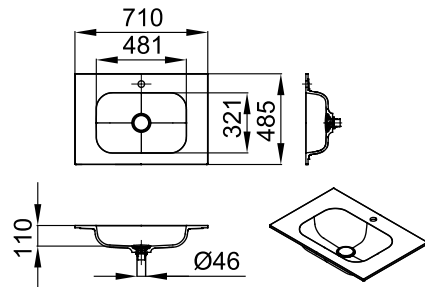

- 108
- 129

## ASTORIA 810-V

810 mm / 485 mm / 110 mm / ø46 mm

- ④\*
- ⑧
- ⑨

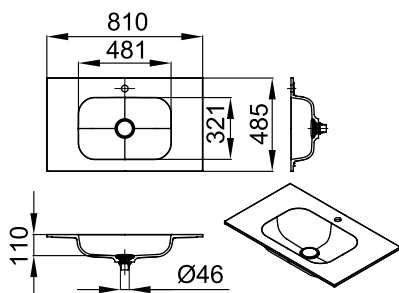

- 108
- 129

## ASTORIA 910-V

910 mm / 485 mm / 110 mm / ø46 mm

- ④\*
- ⑧
- ⑨

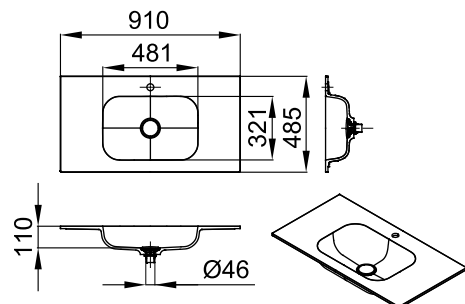

- 108
- 129

# VANITY TOPS. WASCHBECKEN. LAVABOS.

ASTORIA 1210 D-V

1210 mm / 485 mm / 110 mm / Ø46 mm

- ④\*
- ⑧
- ⑨

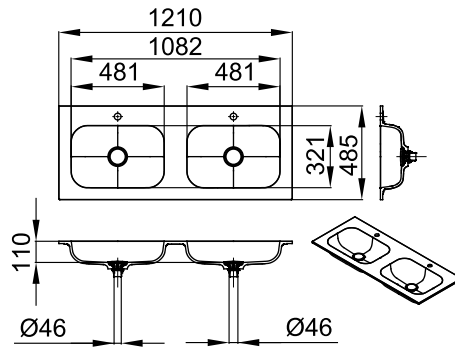
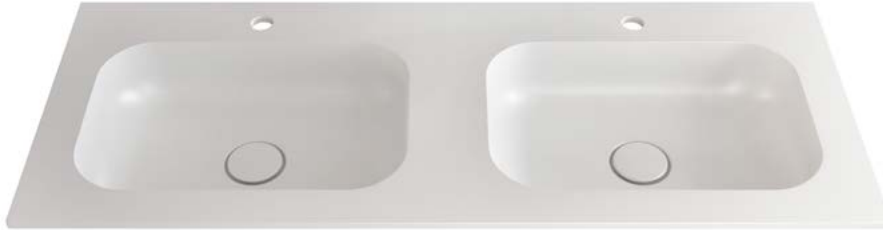

108

129



# WASHBASINS. WASCHBECKEN. VASQUES.

## WASHBASIN. WASCHBECKEN. VASQUES.

## SIPHONES. SIPHONS. SIPHONS.

<b>SOFT 380 V-ON</b>	ø 366 mm / 109 mm / ø 46 mm	4* 8 9
<b>SOFT 380 V-IN</b>	ø 366 mm / 109 mm / ø 46 mm	4* 8 9
<b>SOFT 380 V-UN</b>	ø 366 mm / 109 mm / ø 46 mm	4* 8 9
<b>SOFT 550 V-IN</b>	535 mm / 345 mm / 109 mm / ø 46 mm	4* 8 9
<b>SOFT 550 V-ON</b>	536 mm / 346 mm / 109 mm / ø 46 mm	4* 8 9
<b>SOFT 550 V-UN</b>	536 mm / 346 mm / 109 mm / ø 46 mm	4* 8 9
<b>GLORIA 580 V-IN</b>	547 mm / 367 mm / 100 mm / ø 46 mm	4* 8 9
<b>GLORIA 580 V-UN</b>	547 mm / 367 mm / 100 mm / ø 46 mm	4* 8 9
<b>GLORIA 880 V-IN</b>	848 mm / 368 mm / 100 mm / ø 46 mm	4* 8 9
<b>GLORIA 880 V-UN</b>	848 mm / 368 mm / 100 mm / ø 46 mm	4* 8 9
<b>LUX 380 V-ON</b>	377 mm / 377 mm / 109 mm / ø 46 mm	4* 8 9
<b>LUX 500 V-ON</b>	497 mm / 357 mm / 109 mm / ø 46 mm	4* 8 9
<b>LUX 380 V-IN</b>	378 mm / 378 mm / 109 mm / ø 46 mm	4* 8 9
<b>LUX 500 V-IN</b>	498 mm / 358 mm / 109 mm / ø 46 mm	4* 8 9
<b>LUX 380 V-UN</b>	368 mm / 368 mm / 109 mm / ø 46 mm	4* 8 9
<b>LUX 500 V-UN</b>	487 mm / 347 mm / 109 mm / ø 46 mm	4* 8 9
<b>DEMI V-ON</b>	544 mm / 356 mm / 130 mm / ø 46 mm	4* 8 9
<b>ODA V-ON</b>	550 mm / 425 mm / 109 mm / ø 46 mm	4* 8 9
<b>ARIANA 370 V-ON</b>	354 mm / 354 mm / 119 mm / ø 46 mm	4* 8 9
<b>ARIANA 550 V-ON</b>	534 mm / 354 mm / 119 mm / ø 46 mm	4* 8 9
<b>ARIANA 370 V-UN</b>	354 mm / 354 mm / 119 mm / ø 46 mm	4* 8 9
<b>ARIANA 550 V-UN</b>	534 mm / 354 mm / 119 mm / ø 46 mm	4* 8 9
<b>KIARA 450-UN</b>	450 mm / 300 mm / 74 mm / ø46 mm	7** 8 9
<b>KIARA 450 V-UN</b>	450 mm / 300 mm / 74 mm / ø46 mm	1 7 8 9
<b>KIARA 500-UN</b>	500 mm / 350 mm / 74 mm / ø46 mm	7** 8 9
<b>KIARA 500 V-UN</b>	500 mm / 350 mm / 74 mm / ø46 mm	1 7 8 9
<b>KIARA 700-UN</b>	700 mm / 350 mm / 74 mm / ø46 mm	7** 8 9
<b>KIARA 700 V-UN</b>	700 mm / 350 mm / 74 mm / ø46 mm	1 7 8 9



# VANITY TOPS. WASCHBECKEN. VASQUES.

## VANITY TOP. WASCHBECKEN. VASQUE.

## SIPHONES. SIPHONS. SIPHONS.

**ASTORIA 610-V** 610 mm / 485 mm / 110 mm / ø46 mm

4\* 8 9

**ASTORIA 710-V** 710 mm / 485 mm / 110 mm / ø46 mm

4\* 8 9

**ASTORIA 810-V** 810 mm / 485 mm / 110 mm / ø46 mm

4\* 8 9

**ASTORIA 910-V** 910 mm / 485 mm / 110 mm / ø46 mm

4\* 8 9

**ASTORIA 1210 D-V** 1210 mm / 485 mm / 110 mm / ø46 mm

4\* 8 9



1 SIPHON FI 46 FOR BOWL



4 DRAIN/BOWL WITHOUT O/ TYP 2/KERR 108



7 DRAIN KIARA FOR BOWL WITHOUT O/CR/FI 46



8 SIPHON PVC SPACE SAVING FOR BOWL PVC/ FI 46



9 SIPHON FOR BOWL/ CR/FI 46

\* Drain included / Ablauf inklusive / Drain inclus

\*\* Built-in drain / Die Entwässerung ist eingebaut / Le drainage est intégré





# Custom made vanity tops and washbasins

Your wish is never too demanding for us. Or too easy.  
It's always customised.

# Maßgefertigte Waschtische und Waschbecken

Ihr Wunsch ist für uns nie zu groß. Oder zu klein.  
Es ist immer maßgeschneidert.

# Plans vasques et lavabos sur mesure

Votre souhait n'est jamais trop grand pour nous. Ou trop petit.  
C'est toujours du sur-mesure.



UN – Bowl built under the counter / Becken unter der Arbeitsplatte  
eingebaut / Vasque sous plan

# CUSTOM MADE VANITY TOPS. MAßGEFERTIGTE WASCHTISCHE. PLANS VASQUES SUR MESURE.

TRINITY ✂

TRINITY-E ✂

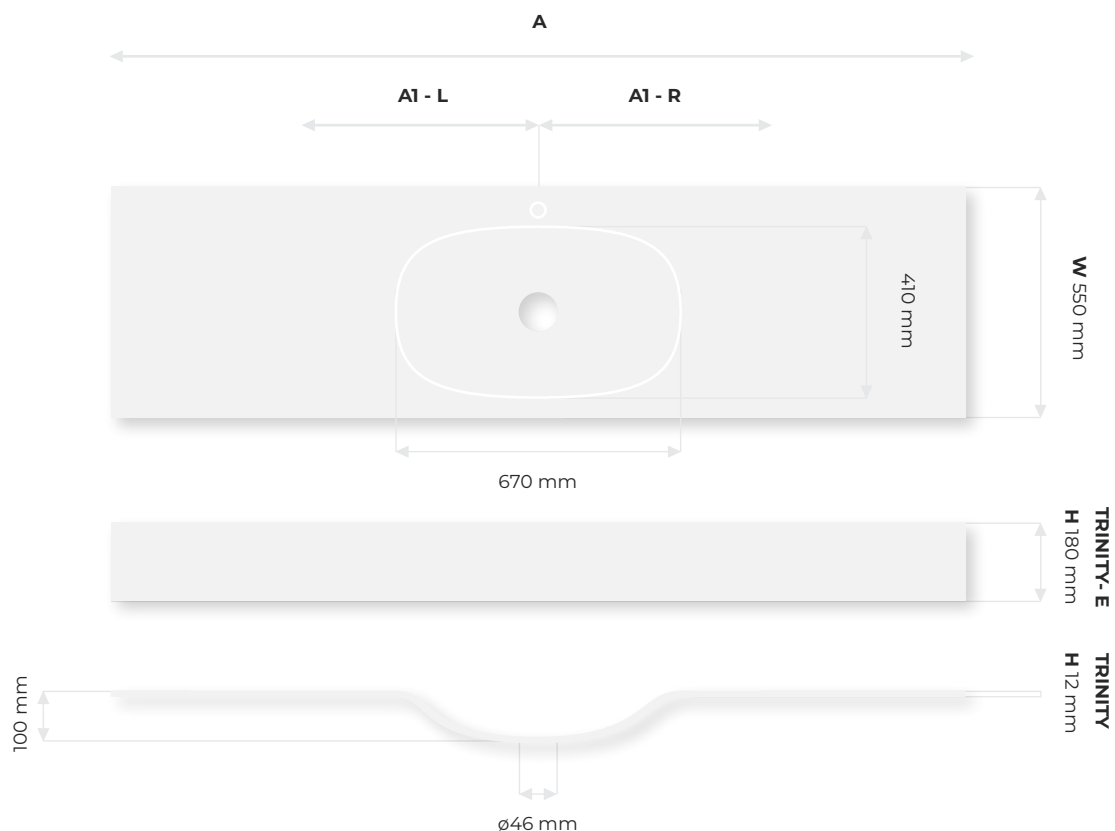

124

108

CUSTOM SIZE. ABMESSUNGEN NACH MASS. TAILLE PERSONNALISÉE.

A 750 - 2900 mm

A1 - L 375 - 1450 mm  
A1 - R

# CUSTOM MADE VANITY TOPS. MAßGEFERTIGTE WASCHTISCHE. PLANS VASQUES SUR MESURE.

TRINITY D ✂

TRINITY-E D ✂

①  
⑤  
⑥  
⑨



①  
⑤  
⑥  
⑨

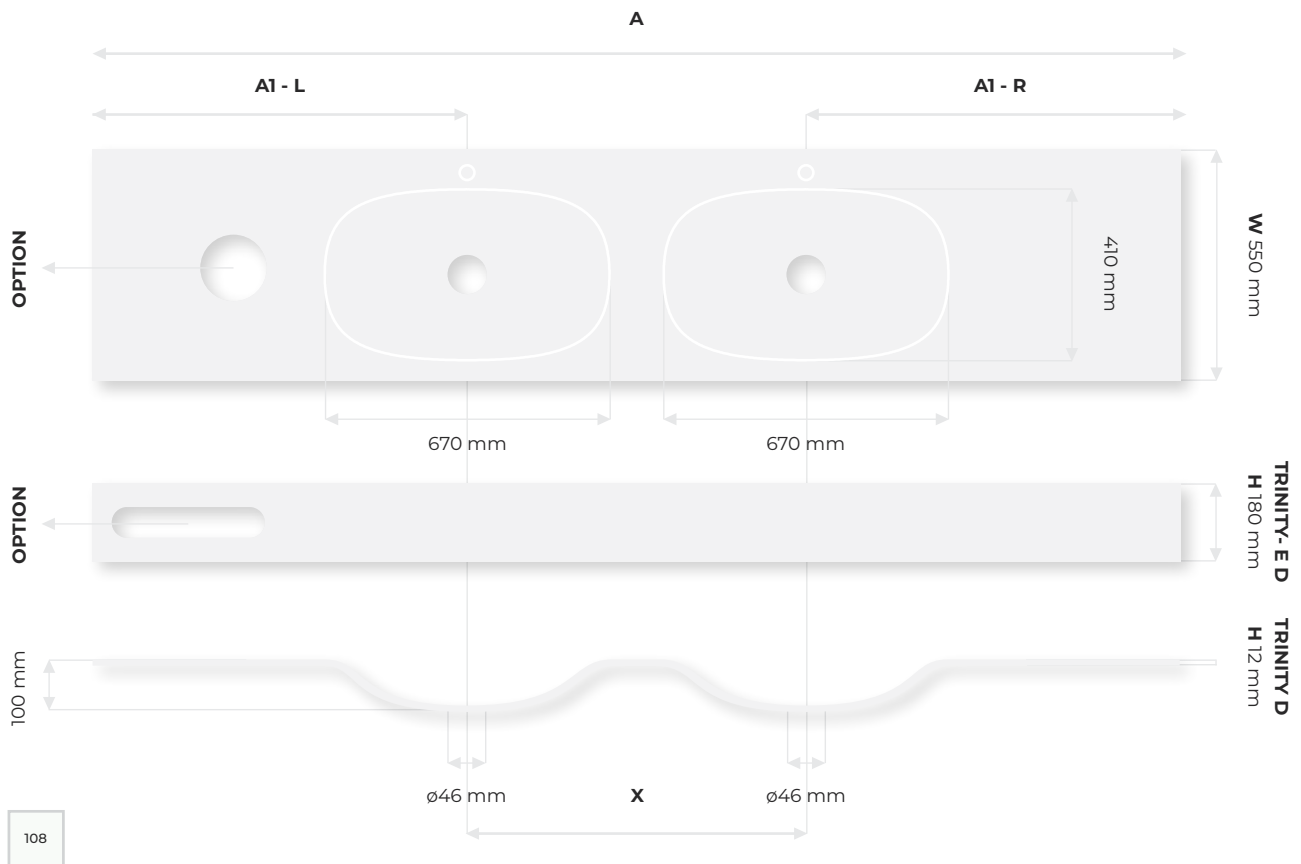

125

CUSTOM SIZE. ABMESSUNGEN NACH MASS. TAILLE PERSONNALISÉE.

A	1600 - 1699 mm	1700 - 1799 mm	1800 - 1899 mm	1900 - 2900 mm
X	820 mm	820 mm 920 mm	820 mm 920 mm 1020 mm	820 mm 920 mm 1020 mm 1120 mm
AI - L AI - R	390 - 890 mm	390 - 890 mm	390 - 890 mm	390 - 890 mm

X = Bowl spacing / Abstand zwischen den Becken / Espacement entre les vasques

OPTION = waste and/or towel opening / Müllöffnung und/oder Handtuchöffnung / Compartiment à poubelles et/ou à serviettes

# CUSTOM MADE WASHBASINS. MAßGEFERTIGTE WASHBECKEN. LAVABOS SUR MESURE.

NOLA-UN 

- ①
- ⑤
- ⑥
- ⑧
- ⑨

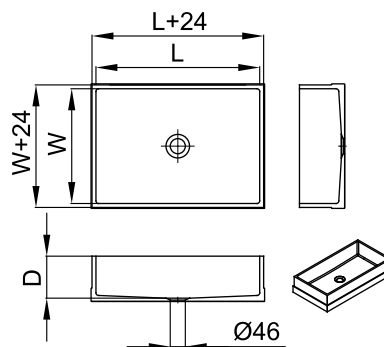

L 300 - 1200 mm



W 300 - 400 mm

126



UNI LIGHT



UNI DARK



GRANIT



TERRAZZO

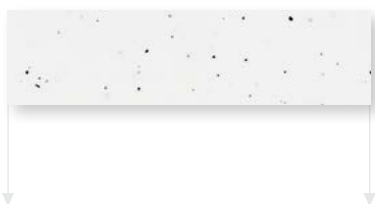

D 50 - 120 mm

CUSTOM SIZE. ABMESSUNGEN NACH MASS. TAILLE PERSONNALISÉE.

NOLA

L 300 - 1200 mm

W 300 - 400 mm

D 50 - 120 mm

L = Length / Länge / Longueur W = Width / Breite / Largeur D = Depth / Tiefe / Profondeur

# CUSTOM MADE WASHBASINS. MAßGEFERTIGTE WASHBECKEN. LAVABOS SUR MESURE.

ZARA-UN  

- ①
- ⑤
- ⑥
- ⑧
- ⑨

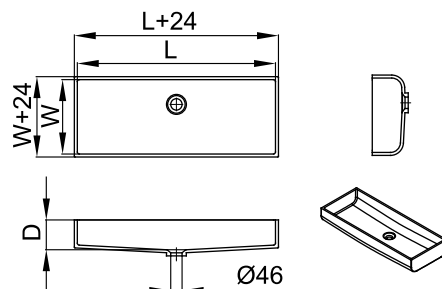

- 100
- 108
- 129
- 503
- 901
- 1090
- 1076
- 5080
- 9095

L 300 - 1200 mm

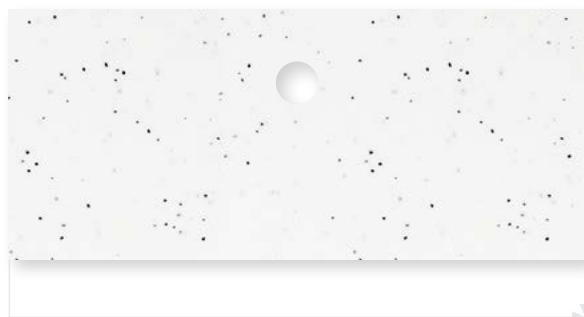

W 300 and 350 mm



D 120 mm

CUSTOM SIZE. ABMESSUNGEN NACH MASS. TAILLE PERSONNALISÉE.

ZARA

L 300 - 1200 mm

W 300 and 350 mm

D 120 mm

L = Length / Länge / Longueur W = Width / Breite / Largeur D = Depth / Tiefe / Profondeur

# CUSTOM MADE WASHBASINS. MAßGEFERTIGTE WASHBECKEN. LAVABOS SUR MESURE.

LUNA-UN  

- ①
- ⑤
- ⑥
- ⑧
- ⑨

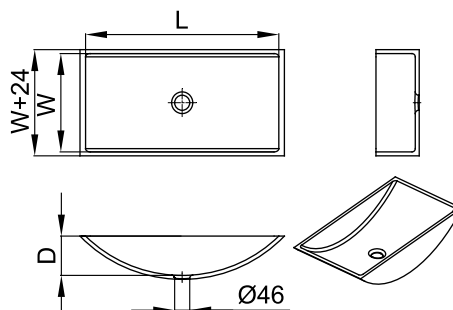

L 300 - 1200 mm

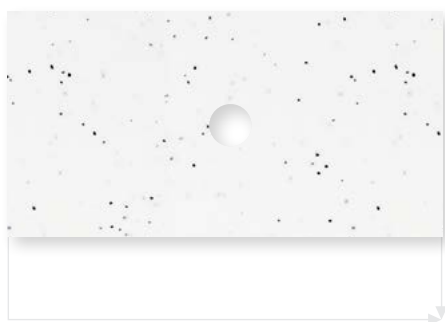

W 300 - 400 mm

128



UNI LIGHT



UNI DARK



GRANIT



TERRAZZO



D 50 - 120 mm

CUSTOM SIZE. ABMESSUNGEN NACH MASS. TAILLE PERSONNALISÉE.

LUNA

L 300 - 1200 mm

W 300 - 400 mm

D 50 - 120 mm



L = Length / Länge / Longueur W = Width / Breite / Largeur D = Depth / Tiefe / Profondeur



# CUSTOM MADE VANITY TOPS AND WASHBASINS. MAßGEFERTIGTE WASCHTISCHE UND WASCHBECKEN. PLANS VASQUES ET LAVABOS SUR MESURE.

VANITY TOP. WASCHBECKEN. VASQUE.

SIPHONES. SIPHONS. SIPHONS.

NOLA-UN		1 5 6 8 9
ZARA-UN		1 5 6 8 9
LUNA-UN		1 5 6 8 9
TRINITY		1 5 6 9
TRINITY-E		1 5 6 9
TRINITY D		1 5 6 9
TRINITY-E D		1 5 6 9



1 SIPHON FI 46 FOR BOWL



5 DRAIN/BOWL WITHOUT O/ CR/FI 46



6 DRAIN/BOWL WITHOUT O/ KERR 108/FI 46



8 SIPHON PVC SPACE SAVING FOR BOWL PVC/fi 46



9 SIPHON FOR BOWL/ CR/FI 46



# Kitchen sinks

A Kerrock sink will bring every kitchen together and complete it aesthetically. With its durable character and sustainable composition, it will remain your faithful cooking assistant for a long time.

# Küchenspülen

Eine Kerrock-Spüle verbindet jede Küche und vervollständigt sie ästhetisch. Mit ihrem langlebigen Charakter und ihrer nachhaltigen Zusammensetzung wird sie Ihnen lange Zeit ein treuer Küchenhelfer sein.

# Éviers de cuisine

L'évier Kerrock apporte une touche d'harmonie et d'esthétique à votre cuisine. Grâce à son caractère durable et à sa composition durable, il restera longtemps votre fidèle assistant culinaire.

There may be variations in shade between bowls and sheets of the same colour. Actual dimensions may differ from those shown (from the plan).

Zwischen Spülen und Platten der gleichen Farbe kann es zu Farbabweichungen kommen. Die tatsächlichen Abmessungen können von den gezeigten (aus dem Plan) abweichen.

Il peut y avoir des variations de teinte entre les vasques et les panneaux d'une même couleur. Les dimensions réelles peuvent différer de celles indiquées (sur le plan).



UN – Bowl built under the counter / Schüssel unter der Arbeitsplatte eingebaut / Vasque sous plan

# KITCHEN SINKS. KÜCHENSPÜLEN. ÉVIERS DE CUISINE.

## ALYA-UN

290 mm / 400 mm / 175 mm / ø 90 mm

10



100

108

129

503

901

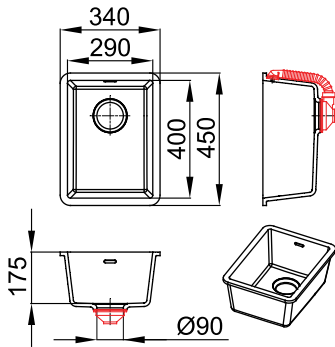

## FLORA-UN

400 mm / 400 mm / 175 mm / ø 90 mm

10



100

108

129

503

901

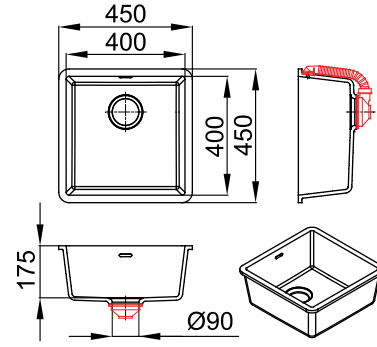

132

## CORA-UN

500 mm / 400 mm / 175 mm / ø 90 mm

10



100

108

129

503

901

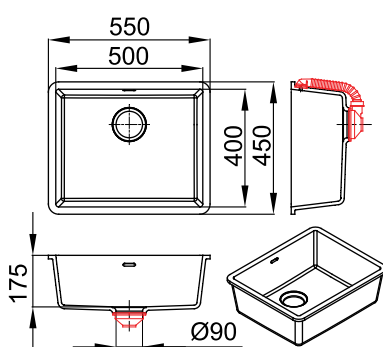

## BETA-UN

700 mm / 400 mm / 175 mm / ø 90 mm

10



100

108

129

503

901

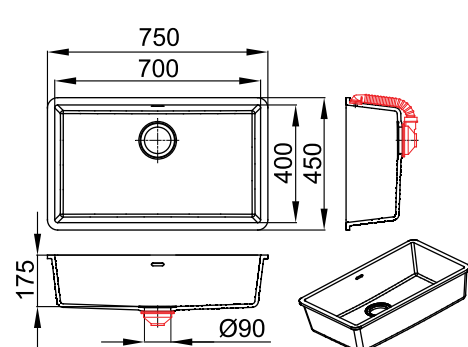

# KITCHEN SINKS. KÜCHENSPÜLEN. ÉVIERS DE CUISINE.

## SONIA-UN

370 mm / 210 mm / 180 mm /  $\varnothing$  90 mm

10

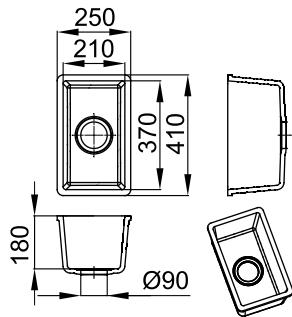

## EMMA-UN

370 mm / 370 mm / 180 mm /  $\varnothing$  90 mm

10

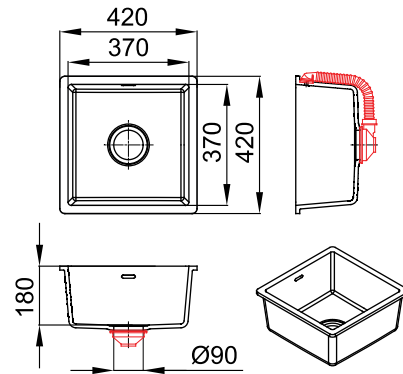
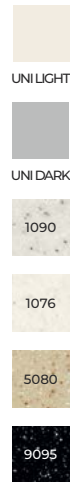

## NADIA-UN

490 mm / 370 mm / 180 mm /  $\varnothing$  90 mm

10

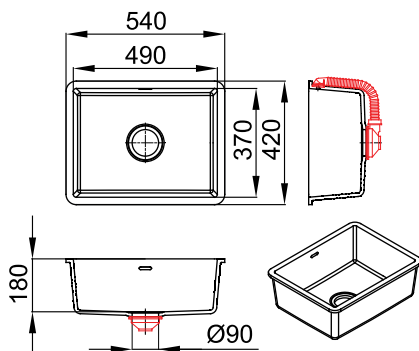

## PIKA-UN

305 mm / 160 mm / 117 mm /  $\varnothing$  90 mm

10

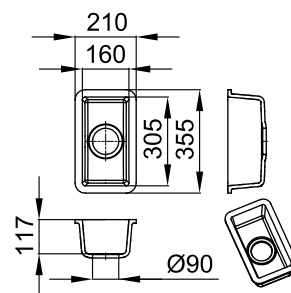

# KITCHEN SINKS. KÜCHENSPIULEN. ÉVIERS DE CUISINE.

## KHLOE-UN

555 mm / 430 mm / 213 mm / ø 90 mm

10

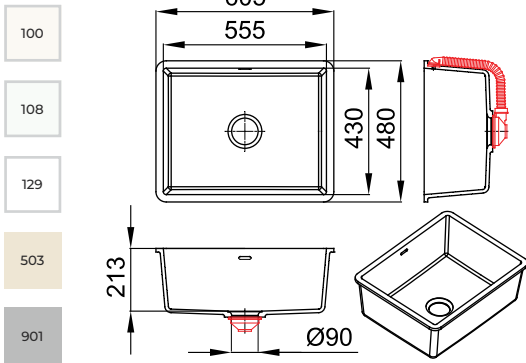

## ALITA-UN

ø 400 mm / 180 mm / ø 90 mm

10

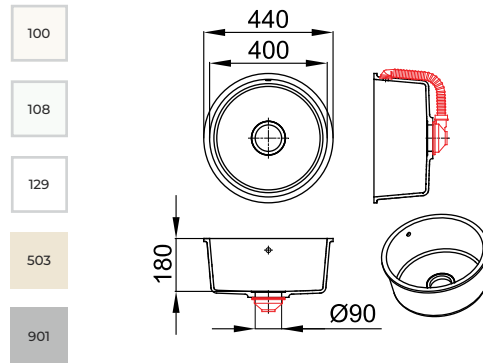

## HELEN-UN

820 mm / 400 mm / 175 mm / ø 90 mm

11

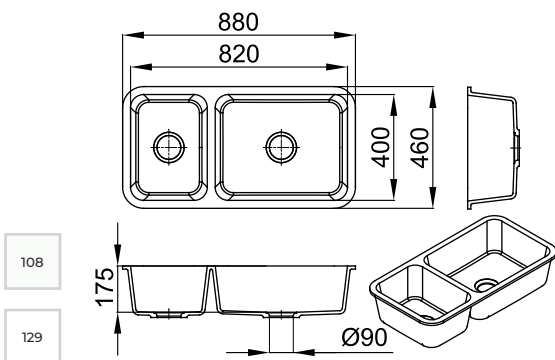

# KITCHEN SINKS. KÜCHENSPIJLEN. ÉVIERS DE CUISINE.

## KITCHEN SINKS. KÜCHENSPIJLEN. ÉVIERS DE CUISINE.

## SIPHONES. SIPHONS. SIPHONS.

**ALYA-UN** 290 mm / 400 mm / 175 mm / ø 90 mm

10

**FLORA-UN** 400 mm / 400 mm / 175 mm / ø 90 mm

10

**CORA-UN** 500 mm / 400 mm / 175 mm / ø 90 mm

10

**BETA-UN** 700 mm / 400 mm / 175 mm / ø 90 mm

10

**SONIA-UN** 370 mm / 210 mm / 180 mm / ø 90 mm

10

**EMMA-UN** 370 mm / 370 mm / 180 mm / ø 90 mm

10

**NADIA-UN** 490 mm / 370 mm / 180 mm / ø 90 mm

10

**PIKA-UN** 305 mm / 160 mm / 117 mm / ø 90 mm

10

**KHLOE-UN** 555 mm / 430 mm / 213 mm / ø 90 mm

10

**ALITA-UN** ø 400 mm / 180 mm / ø 90 mm

10

**HELEN-UN** 820 mm / 400 mm / 175 mm / ø 90 mm

11



10 SIPHON FOR KIT.SINKS/  
SINGLE/FI90



11 SIPHON FOR KIT.SINKS/  
DOUBLE/FI90

# KERROCK INOX. KERROCK INOX. KERROCK INOX.

ELLA 180-UN 

402 mm / 182 mm / 170 mm /  $\varnothing$  90 mm

10



UNILIGHT



UNIDARK



GRANIT



TERRAZZO

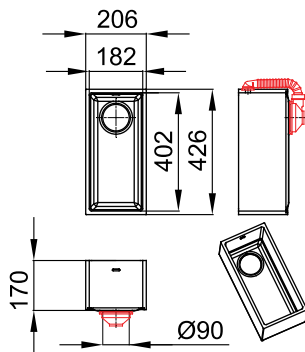

ELLA 340-UN 

402 mm / 342 mm / 170 mm /  $\varnothing$  90 mm

10



UNILIGHT



UNIDARK



GRANIT



TERRAZZO

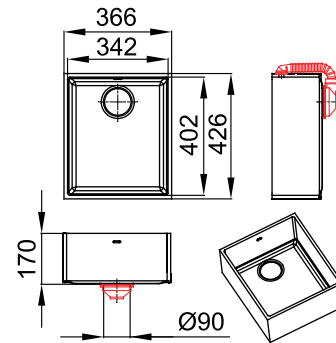

ELLA 400-UN 

402 mm / 402 mm / 170 mm /  $\varnothing$  90 mm

10



UNILIGHT



UNIDARK



GRANIT



TERRAZZO

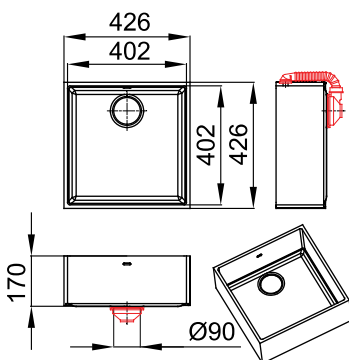

ELLA 500-UN 

502 mm / 402 mm / 170 mm /  $\varnothing$  90 mm

10



UNILIGHT



UNIDARK



GRANIT



TERRAZZO

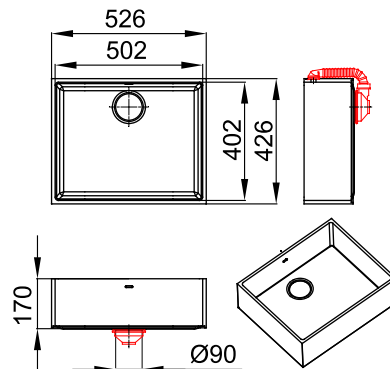



# KERROCK INOX. KERROCK INOX. KERROCK INOX.

## KITCHEN SINKS. KÜCHENSPIJLEN. ÉVIERS DE CUISINE.

## SIPHONES. SIPHONS. SIPHONS.

**ELLA 180-UN** 402 mm / 182 mm / 170 mm / ø 90 mm

10

**ELLA 340-UN** 402 mm / 342 mm / 170 mm / ø 90 mm

10

**ELLA 400-UN** 402 mm / 402 mm / 170 mm / ø 90 mm

10

**ELLA 500-UN** 502 mm / 402 mm / 170 mm / ø 90 mm

10



10 SIPHON FOR KIT.SINKS/  
SINGLE/FI90

# Sinks for laboratories

Working with healthcare professionals, we have created washbasins that are fully ergonomically adapted to specific medical and laboratory applications.

# Waschbecken für Labore

In Zusammenarbeit mit Fachleuten des Gesundheitswesens haben wir Waschtische entwickelt, die vollständig ergonomisch an spezifische medizinische und Laboranwendungen angepasst sind.

# Cuves pour laboratoires

En collaboration avec des professionnels de la santé, nous avons créé des bassins entièrement ergonomiques adaptés à des applications médicales et de laboratoire spécifiques.

Actual dimensions may differ from those shown (from the plan).

Die tatsächlichen Abmessungen können von den gezeigten (aus dem Plan) abweichen.

Les dimensions réelles peuvent différer de celles indiquées (sur le plan).



UN – Bowl built under the counter / Schüssel unter der Arbeitsplatte eingebaut / Vasque construit sous le comptoir

# SINKS FOR LABORATORIES. WASCHBECKEN FÜR LABORE. CUVES POUR LABORATOIRES.

AVA-UN 

400 mm / 400 mm / 300 mm / ø 90 mm

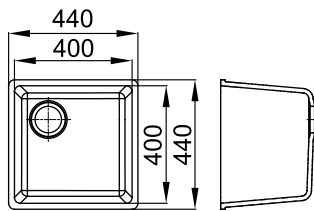

129

108

UNI LIGHT

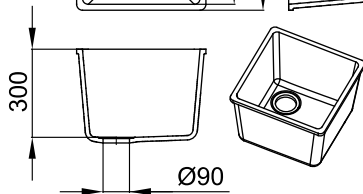

CARA-UN 

500 mm / 400 mm / 300 mm / ø 90 mm

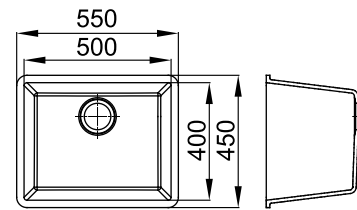

129

108

UNI LIGHT

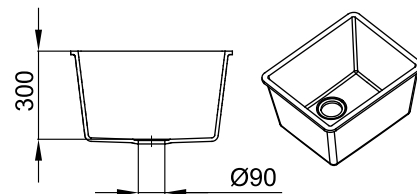

## SINKS FOR LABORATORIES. WASCHBECKEN FÜR LABORE. CUVES POUR LABORATOIRES.

## SIPHONES. SIPHONS. SIPHONS.

**AVA** 400 mm / 400 mm / 300 mm / ø 90 mm

10

**CARA** 500 mm / 400 mm / 300 mm / ø 90 mm

10



10 SIPHON FOR KIT.SINKS/  
SINGLE/F190





# Bathtubs

Feel the warmth that only Kerrock can offer when it touches your skin. Wrap yourself in the safe embrace of sophisticated ergonomics and the relaxation that comes from thoughtful water play.

# Badewannen

Spüren Sie die Wärme, die nur Kerrock bieten kann, wenn es Ihre Haut berührt. Hüllen Sie sich in die sichere Umarmung einer ausgeklügelten Ergonomie und in die Entspannung, die ein durchdachtes Wasserspiel mit sich bringt.

# Baignoires

Sentez la chaleur que seul Kerrock peut vous offrir en touchant votre peau. Enveloppez-vous dans l'étreinte sûre d'une ergonomie sophistiquée et laissez-vous porter par la détente que procurent des jeux d'eau bien pensés.

There may be variations in shade between bowls and sheets of the same colour. Actual dimensions may differ from those shown (from the plan).

Zwischen Wannen und Platten der gleichen Farbe kann es zu Farbabweichungen kommen. Die tatsächlichen Abmessungen können von den gezeigten (aus dem Plan) abweichen.

Il peut y avoir des variations de teinte entre les vasques et les panneaux d'une même couleur. Les dimensions réelles peuvent différer de celles indiquées (sur le plan).



UN – Bowl built under the counter / Schüssel unter der Arbeitsplatte eingebaut / Vasque sous plan

# BABY BATHTUBS. BADEWANNEN FÜR KINDER. BAIGNOIRES POUR ENFANTS.

## HEIDI-UN

550 mm / 350 mm / 183 mm / ø 46 mm

- ①
- ⑤
- ⑥
- ⑦
- ⑧
- ⑨

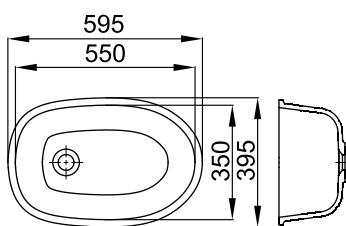

- 108
- 129

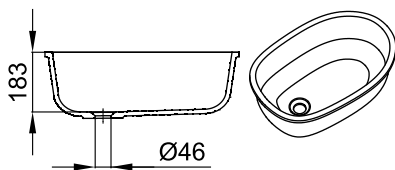

## SOFIA-UN

700 mm / 400 mm / 250 mm / ø 46 mm

- ①
- ⑤
- ⑥
- ⑦
- ⑧
- ⑨

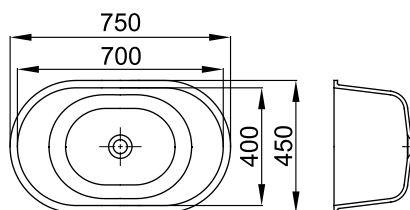

- 108
- 129

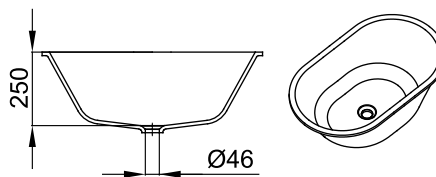

## ADA-UN

850 mm / 450 mm / 250 mm / ø 46 mm

- ①
- ⑤
- ⑥
- ⑦
- ⑧
- ⑨

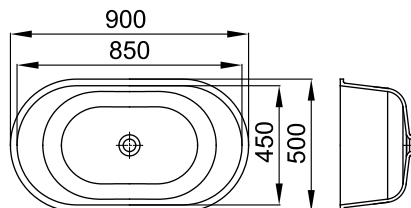

- 108
- 129

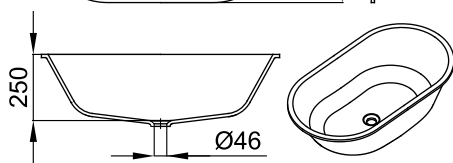

# BATHTUBS. BADEWANNEN. BAIGNOIRES.

## ATYS-UN

1672 mm / 640 mm / 450 mm / ø 52 mm

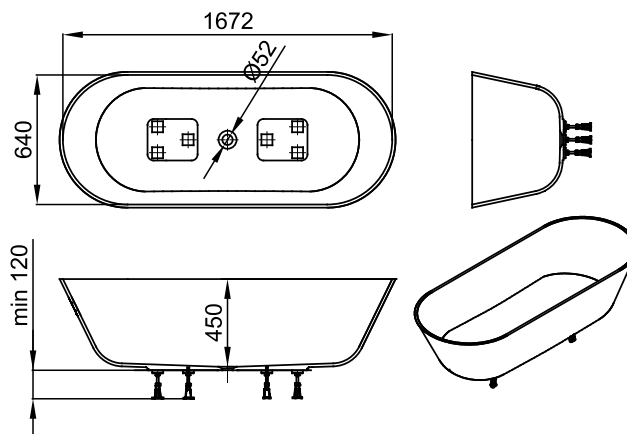

108

Supplied with feet and click-clack overflow kit. / Wird mit Füßen und Click-Clack-Überlaufset geliefert. / Fourni avec des pieds et un kit de trop-plein à encliqueter.

### BABY BATHTUBS. BADEWANNEN FÜR KINDER. BAIGNOIRES POUR ENFANTS.

### SIPHONES. SIPHONS. SIPHONS.

**HEIDI-UN** 550 mm / 350 mm / 183 mm / ø 46 mm

1 5 6 7 8 9

**SOFIA-UN** 700 mm / 400 mm / 250 mm / ø 46 mm

1 5 6 7 8 9

**ADA-UN** 850 mm / 450 mm / 250 mm / ø 46 mm

1 5 6 7 8 9



1 SIPHON FI 46 FOR BOWL



5 DRAIN/BOWL WITHOUT O/CR/FI 46



6 DRAIN/BOWL WITHOUT O/KERR 108/FI 46



7 DRAIN KIARA FOR BOWL WITHOUT O/CR/FI 46



8 SIPHON PVC SPACE SAVING FOR BOWL PVC/fi 46



9 SIPHON FOR BOWL/CR/FI 46







# Bathroom equipment

Enter a space of intimacy that offers you the highest standards of safety, quality and sustainability. A world of details that will take you to a unique experience of comfort and harmony every time.

*APPLICATION: Bathtubs/shower trays/massage columns made of Kerrock material*

# Badzubehör

Betreten Sie einen Raum der Intimität, der Ihnen die höchsten Standards für Sicherheit, Qualität und Nachhaltigkeit bietet. Eine Welt voller Details, die Sie jedes Mal zu einem einzigartigen Erlebnis von Komfort und Harmonie führt.

*ANWENDUNG: Badewannen/Duschwannen/Massagesäulen aus dem Material Kerrock*

145

# Équipement de salle de bains

Entrez dans un espace d'intimité qui vous offre les normes les plus élevées en matière de sécurité, de qualité et de durabilité. Un monde de détails qui vous fera vivre à chaque fois une expérience unique de confort et d'harmonie.

*APPLICATION : Baignoires/douches/colonnes de massage en Kerrock*

There may be variations in shade between bowls and sheets of the same colour. Actual dimensions may differ from those shown (from the plan).

Zwischen Wannen und Platten der gleichen Farbe kann es zu Farbabweichungen kommen. Die tatsächlichen Abmessungen können von den gezeigten (aus dem Plan) abweichen.

Il peut y avoir des variations de teinte entre les vasques et les panneaux d'une même couleur. Les dimensions réelles peuvent différer de celles indiquées (sur le plan).

# BATHTUBS. BADEWANNEN. BAIGNOIRES.

## LOTOS-FS

1970 mm / 1170 mm / 590 mm /  $\varnothing$ 52 mm

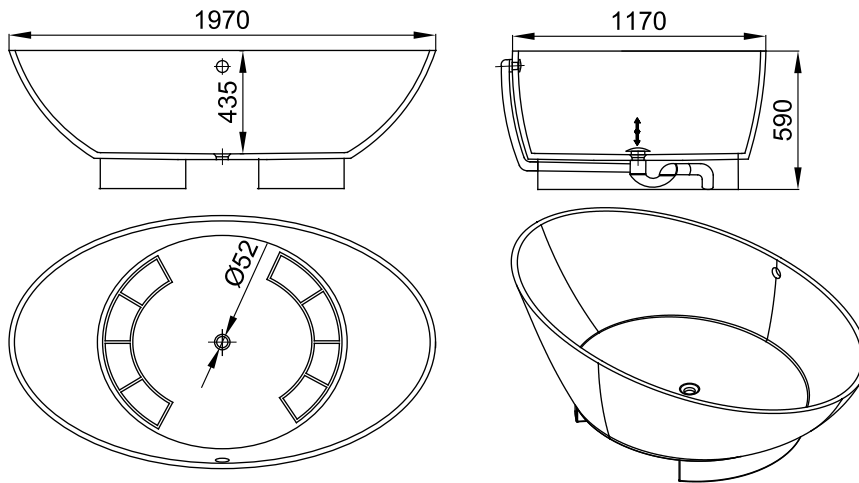

108

Oval freestanding Kerrock bathtub, with chrome overflow set.

Ovale freistehende Badewanne aus Kerrock, mit verchromter Überlaufgarnitur.

Baignoire ovale en Kerrock. Autoportante, avec finition chromée sur l'extérieur de la baignoire.

146



# BATHTUBS. BADEWANNEN. BAIGNOIRES.

## FREYA-FS

1810 mm / 860 mm / 590 mm / ø52 mm

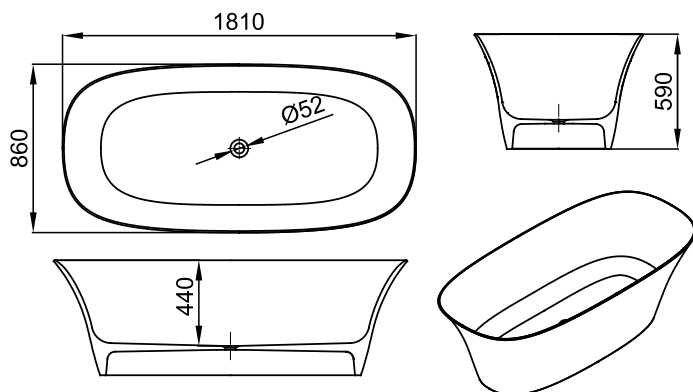

108

Oval freestanding Kerrock bathtub, outflow set with the UP&DOWN system.

Ovale freistehende Badewanne aus Kerrock, Ab- und Überlaufgarnitur mit UP & DOWN System.

Baignoire ovale en Kerrock. Autoportante, garniture d'écoulement avec système UP&DOWN.



147

# BATHTUBS. BADEWANNEN. BAIGNOIRES.

## ROSE-FS

1800 mm / 800 mm / 595 mm / ø52 mm

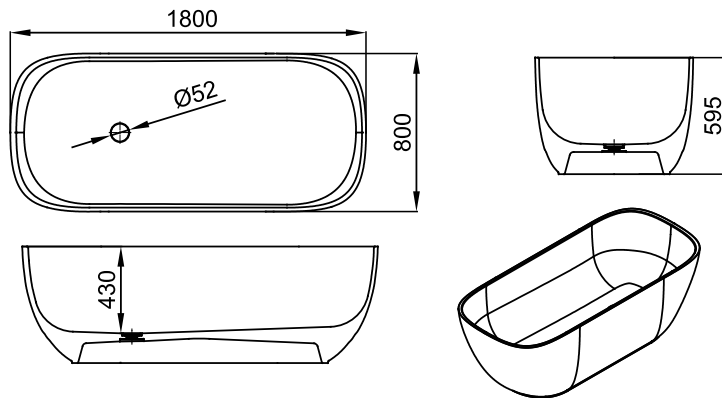

108

Oval freestanding Kerrock bathtub, outflow set with the UP&DOWN system.  
Ovale freistehende Badewanne aus Kerrock, Ab- und Überlaufgarnitur mit UP & DOWN System.  
Baignoire ovale en Kerrock. Autoportante, garniture d'écoulement avec système UP&DOWN.

148



# BATHTUBS. BADEWANNEN. BAIGNOIRES.

## RUBY-FS

1800 mm / 800 mm / 570 mm /  $\varnothing$ 52 mm

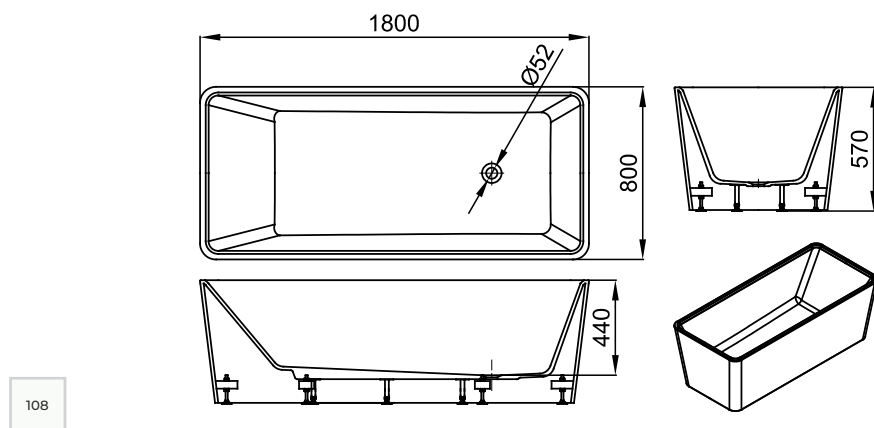

108

Freestanding Kerrock bathtub, outflow set with the UP&DOWN system.  
Freistehende Kerrock-Badewanne, Ablaufgarnitur mit UP&DOWN-System.  
Baignoire en Kerrock. Autoportante, garniture d'écoulement avec système UP&DOWN.



# BATHTUBS. BADEWANNEN. BAIGNOIRES.

## ASTRA DUO-FS

1735 mm / 700 mm / 600 mm /  $\varnothing$ 52 mm

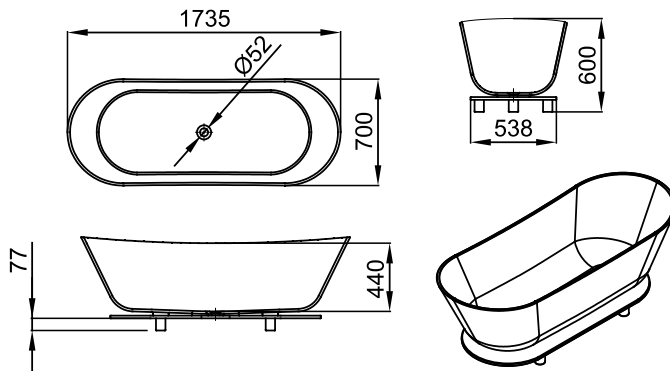

108

Freestanding Kerrock bathtub, outflow set with the UP&DOWN system.

Freistehende Badewanne aus Kerrock, Ablaufgarnitur mit UP & DOWN System.

Baignoire autoportante en Kerrock. Garniture d'écoulement avec le système UP&DOWN. Base de support Kerrock, couleur 909.

150



# BATHTUBS. BADEWANNEN. BAIGNOIRES.

ASTRA / O

1800 mm / 850 mm / 600 mm /  $\varnothing 52$  mm

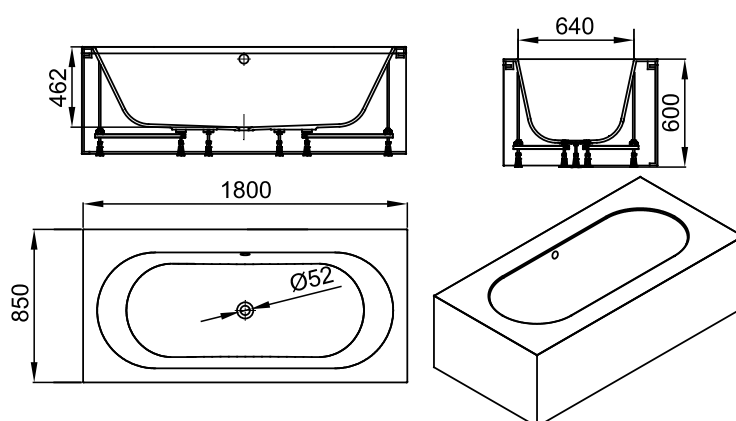

108

Freestanding Kerrock bathtub with panel, outflow-overflow set with the UP&DOWN system.

Freistehende Badewanne aus Kerrock mit Schürze, Ab- und Überlaufgarnitur mit UP & DOWN System.

Baignoire autoportante avec revêtement en Kerrock. Kit de trop-plein avec système UP&DOWN.



# BATHTUBS. BADEWANNEN. BAIGNOIRES.

## ASTRA-FS

1800 mm / 850 mm / 600 mm /  $\varnothing$ 52 mm

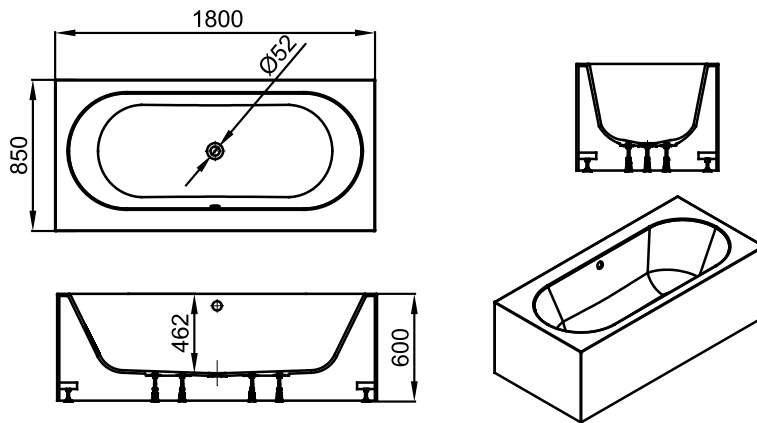

108

Freestanding Kerrock bathtub, outflow-overflow set with the UP&DOWN system.  
Freistehende Badewanne aus Kerrock, Ab- und Überlaufgarnitur mit UP & DOWN System.  
Baignoire autoportante en Kerrock. Kit de trop-plein avec système UP&DOWN.

152





# BATHTUBS. BADEWANNEN. BAIGNOIRES.

ASTRA ✂

2000 mm / 1000 mm / 618 mm / ø52 mm

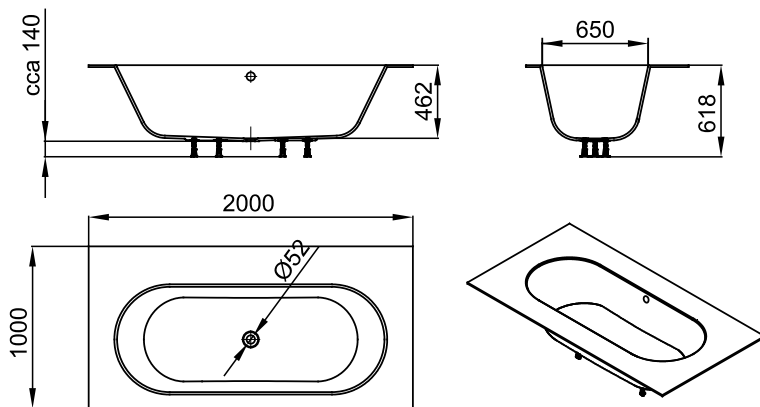

108

Kerrock bathtub, outflow-overflow set with the UP&DOWN system, installation on tiles or in tile-level, possibility of trimming the edge of the bathtub.  
Badewanne aus Kerrock, Ab- und Überlaufgarnitur mit UP & DOWN System, Badewanneneinbau auf Bodenfliesen bzw. aufs Bodenfliesen-Niveau, die Badewannenränder können nach Maß zugeschnitten werden.  
Baignoire en Kerrock. Kit de trop-plein avec système UP&DOWN, pieds de baignoire. Installation sur les plaques ou au niveau des plaques.  
Possibilité de découper le bord de la baignoire.



# BATHTUBS. BADEWANNEN. BAIGNOIRES.

## AMBER-FS

1800 mm / 800 mm / 630 mm /  $\varnothing$ 52 mm

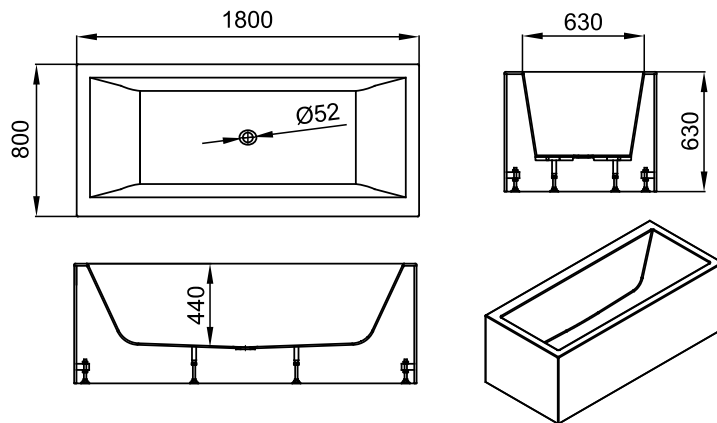

108

Freestanding Kerrock bathtub, outflow set with the UP&DOWN system and automatic overflow.  
Freistehende Badewanne aus Kerrock, Ablaufgarnitur mit UP & DOWN System und automatischem Überlauf.  
Baignoire autoportante en Kerrock. Garniture d'écoulement avec le système UP&DOWN.

154



# BATHTUBS. BADEWANNEN. BAIGNOIRES.

## AMBER LIGHT-FS

1800 mm / 800 mm / 600 mm /  $\varnothing 52$  mm

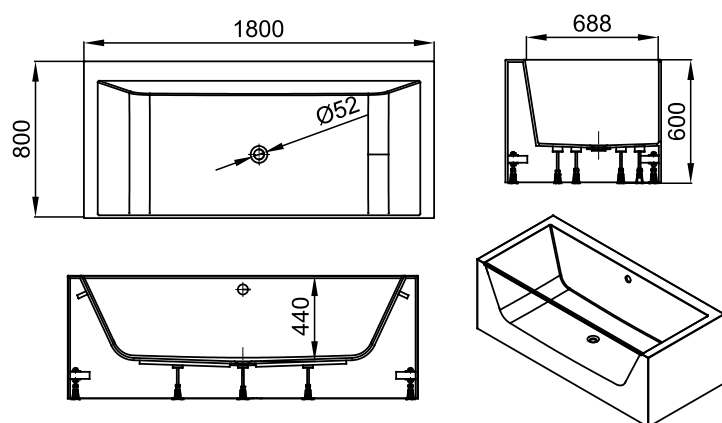

108

Freestanding Kerrock bathtub with transparent acrylic wall, outflow-overflow set with the UP&DOWN system.  
Freistehende Badewanne aus Kerrock, Ab- und Überlaufgarnitur mit UP & DOWN System.  
Baignoire autoportante en Kerrock avec paroi acrylique transparente. Kit de trop-plein avec système UP&DOWN.



# BATHTUBS. BADEWANNEN. BAIGNOIRES.

## AMBER LUX-FS

1800 mm / 1000 mm / 630 mm /  $\varnothing 52$  mm

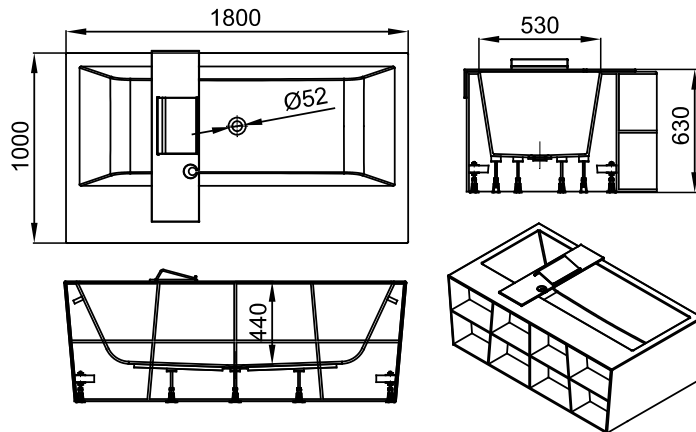

108

Freestanding Kerrock bathtub with shelves and a tub shelf, outflow set with the UP&DOWN system and automatic overflow.

Freistehende Badewanne aus Kerrock, mit integriertem Regal und Badewannenablage, Ablaufgarnitur mit UP&DOWN System und automatischem Überlauf.

Baignoire autoportante en Kerrock avec étagères et tablette de rangement pour la baignoire. Garniture d'écoulement avec le système UP&DOWN.

156



# SHOWER TRAYS. DUSCHWANNEN. RECEVEURS DE DOUCHE.

CORAL ✂

12  
13

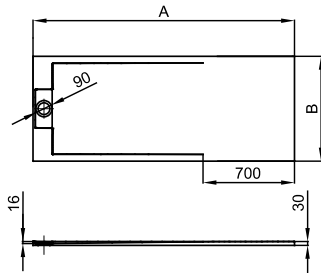

108

CORAL	A	B	VM
200 x 90 (80)	2000	900 (800)	30
140 x 90 (80)	1400	900 (800)	30

Shower tray for built-in installation or fixing on the floor, made from Kerrock.  
 Duschwanne aus Kerrock für den Einbau oder zur Bodenaufstellung.  
 Receveur de douche à installer ou monter au sol en Kerrock. Possibilité de découpe.



# SHOWER TRAYS. DUSCHWANNEN. RECEVEURS DE DOUCHE.

ARON ✂

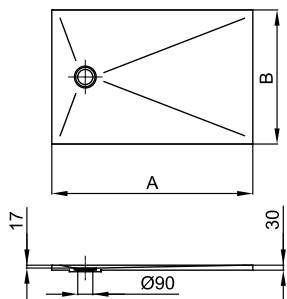

108

ARON	A	B	VM
160 x 90 (80)	1600	900 (800)	30
140 x 90 (80)	1400	900 (800)	30
120 x 90 (80)	1200	900 (800)	30
100 x 80	1000	800	30
90 x 90	900	900	30

158

Shower tray for built-in installation or fixing on the floor, made from Kerrock, siphon included. Possibility of trimming to the specified dimensions.  
 Duschwanne aus Kerrock für den Einbau oder zur Bodenaufstellung, mit mitgeliefertem Siphon. Möglichkeit zum Justieren auf die angegebenen Abmessungen.  
 Receveur de douche à installer ou monter au sol en Kerrock, avec siphon inclus. Possibilité de découpe aux dimensions spécifiées.



# SHOWER TRAYS. DUSCHWANNEN. RECEVEURS DE DOUCHE.

## TRENT

14

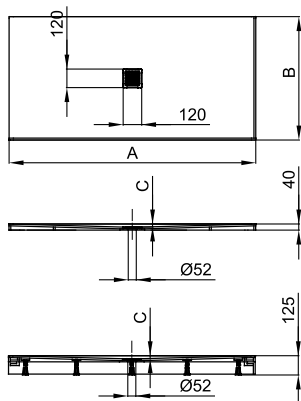

109

9252

TRENT	A	B	C	VM
160 x 90 (80)	1600	900 (800)	20	125
140 x 90 (80)	1400	900 (800)	20	125
120 x 90 (80)	1200	900 (800)	15	125
100 x 100	1000	1000	15	125
90 x 90	900	900	15	125

Shower tray for built-in installation / fixing on the floor / installation at the floor level / with panel, made from Kerrock.  
 Duschwanne aus Kerrock für den Einbau / zur Bodenaufstellung / Bodeneinbau / mit Schürze.  
 Receveur de douche pour installation/installation au sol/pour installation au niveau du sol/avec revêtement, en Kerrock.



# SHOWER TRAYS. DUSCHWANNEN. RECEVEURS DE DOUCHE.

## TRENT R

14

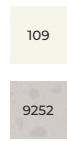
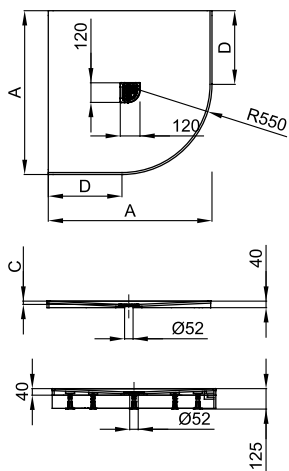

TRENT R	A	C	D	VM
100 x 100	1000	15	450	40
90 x 90	900	15	350	40
100 x 100 / O	1000	15	450	125
90 x 90 / O	900	15	350	125

Shower tray for fixing on the floor / with panel, semi-circular, made from Kerrock / Duschwanne aus Kerrock zur Bodenaufstellung / mit Schürze, halbrund / Douche pour installation au sol/avec revêtement, semi-circulaire, en Kerrock.





# SHOWER TRAYS. DUSCHWANNEN. RECEVEURS DE DOUCHE.

## FOSTER

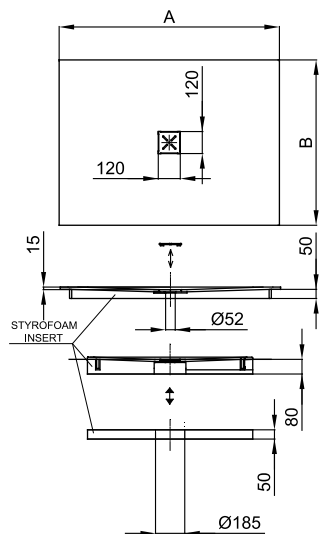

108

FOSTER	A	B	VM
120 x 90 (80)	1200	900 (800)	130
100 x 100	1000	1000	130
90 x 90	900	900	130

Kerrock shower tray, shallow bottom, Installation at the floor level, high-flow  $\text{Ø} 52$  trap, supporting structure, H = 12mm.

Duschwanne aus Kerrock, flacher Boden, Bodeneinbau, high-flux Siphon  $\text{Ø} 52$ , Tragkonstruktion, H = 12mm.

Douche en Kerrock, extra plat, pour installation au niveau du sol. INCLUS: siphon grand débit  $\text{Ø} 52$ , structure de support, H = 12 mm, feuille étanche STOP, insert en polystyrène.



# SHOWER TRAYS. DUSCHWANNEN. RECEVEURS DE DOUCHE.

## RUBY

14

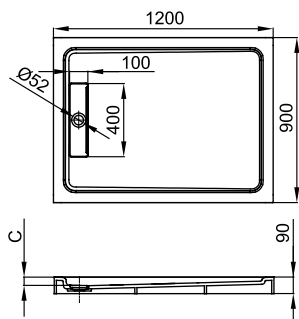

108

RUBY	A	B	C	VM
120 x 90	1200	900	47	90

Shower tray for fixing on the floor, made from Kerrock  
 Duschwanne aus Kerrock zur Bodenaufstellung.  
 Receveur de douche pour installation au sol à Kerrock.

162



# SHOWER TRAYS. DUSCHWANNEN. RECEVEURS DE DOUCHE.

## BOWL. WANNE. VASQUE.

## SIPHONES. SIPHONS. SIPHONS.

CORAL



12 13

ARON



Siphon Ø90 with Kerrock cap H = 60mm included. / Inklusive Siphon Ø 90 mit Kerrock-Kappe H = 60 mm. / Siphon Ø 90 avec bouchon kerrock H = 60 mm inclus.

TRENT

14

TRENT R

14

FOSTER

High-flow siphon Ø52 included. / Siphon mit hohem Durchfluss Ø 52 mitgeliefert. / Siphon à haut débit Ø 52 inclus.

RUBY

14



12 SIPHON FOR SHOWER TRAYS/ WITHOUT COVER H=65 MM/FI 90



13 SIPHON FOR SHOWER TRAYS/ WITHOUT COVER H=84 MM/FI 90



14 SIPHON FOR SHOWER TRAYS/ WITHOUT COVER H=65 MM/FI 52

# SHOWER COLUMNS. DUSCHPANELEE. COLONNES DE DOUCHE.

## SPECTRA FLAT 1600 3F

1600 mm / 230 mm / 580 mm



## SPECTRA 1500 4F

1500 mm / 230 mm / 517 mm



164

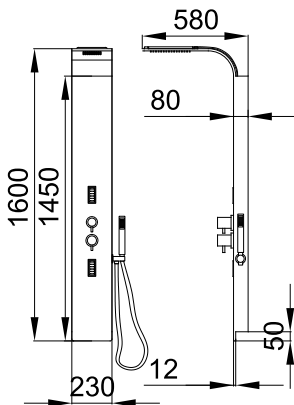

109

9252

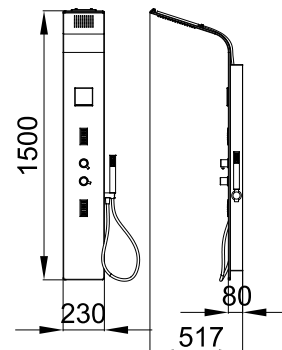

109

9252

System functions: 3-function tap – head shower, upper body massage, lower body massage, hand shower, installation: wall-mounted. / Duschfunktionen: 3-Funktions-Mischbatterie – Kopfbrause, Oberkörpermassage, Unterkörpermassage, Handbrause, Montage: Wand. / Fonctions du système : mitigeur 3 fonctions – douche de tête, massage du haut du corps, massage du bas du corps, douchette, montage mural.

Functions of the system: 4-function tap – head shower, upper body massage, lower body massage, hand shower, cascade, installation: wall-mounted. / Funktionalitäten des Systems: 4-Funktions-Mischbatterie – Kopfbrause, Oberkörpermassage, Unterkörpermassage, Handbrause, Wasserfall, Montage: Wand. / Fonctions du système : mitigeur 4 fonctions – douche de tête, massage du haut du corps, massage du bas du corps, douchette, cascade, montage mural.

# SHOWER COLUMNS. DUSCHPANELEE. COLONNES DE DOUCHE.

## SPECTRA 1500 3F

1500 mm / 230 mm / 517 mm

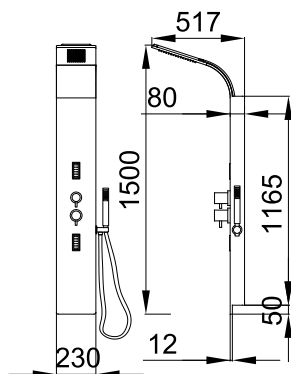

109

9252

System functions: 3-function tap – head shower, upper body massage, lower body massage, hand shower, installation: wall-mounted. / Duschfunktionen: 3-Funktions-Mischbatterie – Kopfbrause, Oberkörpermassage, Unterkörpermassage, Handbrause, Montage: Wand. / Fonctions du système : mitigeur 3 fonctions – douche de tête, massage du haut du corps, massage du bas du corps, douchette, montage mural.

## SUMMIT

1400 mm / 170 mm / 525 mm

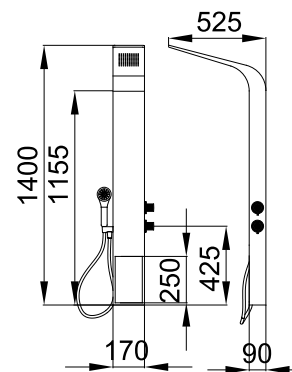

109

9252

System functions: 2-function thermostatic tap – head shower, hand shower, installation: wall-mounted. / Duschfunktionen: Thermostatische 2-Funktions-Mischbatterie – Kopfbrause, Handbrause, Montage: Wand. / Fonctions du système : mitigeur thermostatique 2 fonctions – douche de tête, douchette, montage mural.

# SHOWER COLUMNS. DUSCHPANEELLE. COLONNES DE DOUCHE.

NEXUS

1600 mm / 125 mm / 525 mm



166

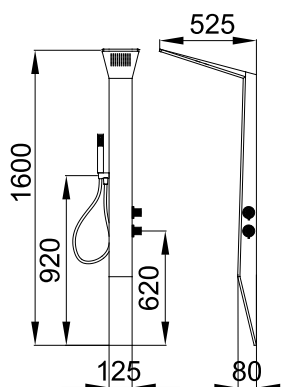

109

9252

System functions: 2-function thermostatic tap – head shower, hand shower,  
installation: wall-mounted. / Duschfunktionen: Thermostatische 2-Funktions-  
Mischbatterie – Kopfbrause, Handbrause, Montage: Wand. / Fonctions du  
système : mitigeur thermostatique 2 fonctions – douche de tête, douchette,  
montage mural.











# Decorative cladding

Whether you want sleek minimalism or a bold colour palette, decorative cladding allows you to create a unique and sophisticated ambience. Transform your space and contribute to the aesthetic pleasure and comfort of your home.

# Dekorative Verkleidung

Ob Sie sich für schlichten Minimalismus oder eine kräftige Farbpalette entscheiden, mit dekorativen Verkleidungen können Sie ein einzigartiges und anspruchsvolles Ambiente schaffen. Verwandeln Sie Ihren Raum und tragen Sie zum ästhetischen Vergnügen und zum Komfort in Ihrem Zuhause.

# Revêtement décoratif

Que vous souhaitiez un minimalisme épuré ou une palette de couleurs audacieuse, les revêtements décoratifs vous permettent de créer une ambiance unique et sophistiquée. Transformez votre espace et contribuez à l'esthétique et au confort de votre maison.

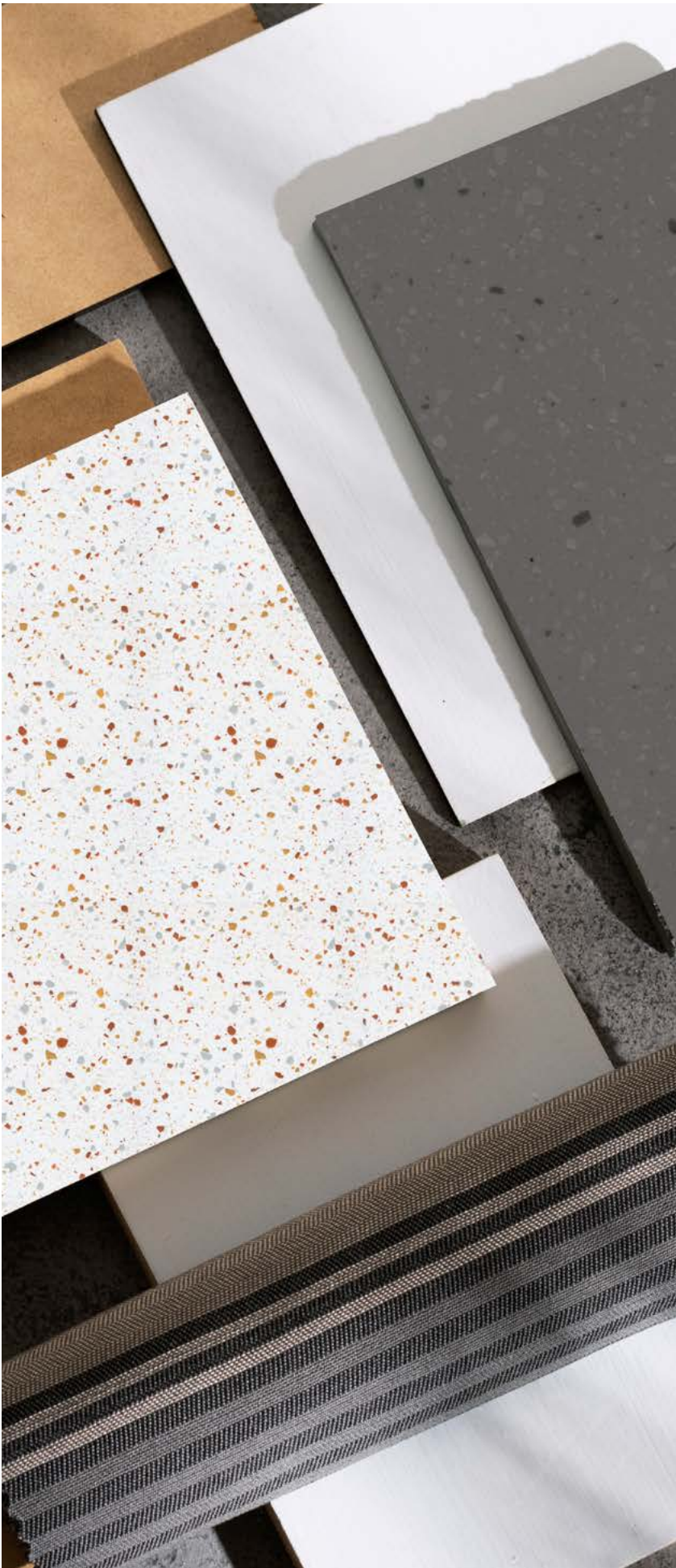





# QuickQube

The bathroom is fully prefabricated in the factory from pre-fabricated elements, allowing two types of assembly: brought already assembled or modularly assembled on site. A practical and quick solution for your bathroom.

# QuickQube

Die Badezelle in der Fabrik aus vorgefertigten Elementen komplett vorbereitet, so dass zwei Arten der Montage möglich sind: bereits montiert mitgebracht oder modular vor Ort montiert. Eine praktische und schnelle Lösung für Ihr Badezimmer.

173

# QuickQube

La salle de bains est entièrement préfabriquée à partir d'éléments préfabriqués, ce qui permet deux types d'assemblage : apportée déjà assemblée ou assemblée modulairement sur place. Une solution pratique et rapide pour votre salle de bains.

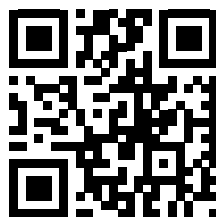

[www.quickqube.com](http://www.quickqube.com)

**Camping Podzemelj**  
Slovenia



174



**Camping Podzemelj**  
Slovenia



# Kerrwall

Do you want a new and, above all, trendy bathroom that won't require major construction work?

Dress it in innovative KERRWALL technology, which allows application with full-size sheets and, in case of renovation, without prior removal of the tiles. Glossy options in different colours, customised or standard dimensions.

Aesthetic and practical choice for every bathroom.

# Kerrwall

Möchten Sie ein neues und vor allem schickes Badezimmer, das keine großen Bauarbeiten erfordert?

Verkleiden Sie es mit der innovativen KERRWALL-Technologie, die die Anwendung mit Platten in voller Größe und im Falle einer Renovierung ohne vorheriges Entfernen der Fliesen ermöglicht. Glänzende Optionen in verschiedenen Farben, maßgeschneiderte oder Standardmaße.

Eine ästhetische und praktische Wahl für jedes Badezimmer.

# Kerrwall

Vous souhaitez une salle de bains neuve et surtout tendance qui ne nécessite pas de gros travaux ?

Changez avec la technologie innovante KERRWALL, qui permet une application avec des plaques plein format et, dans le cas d'une rénovation, sans retrait préalable des plaques. Options brillantes dans différentes couleurs, dimensions personnalisées ou standard.

Un choix esthétique et pratique pour chaque salle de bains.









**Project: Private Bathroom Sascha und Lilli Grewe**

Design: Artcanbreakyourheart – Sascha Grewe

Photography: Benni Janzen



# STANDARD SHEET DIMENSIONS. STANDARD-PLATTENABMESSUNGEN. DIMENSIONS STANDARD DES PANNEAUX.

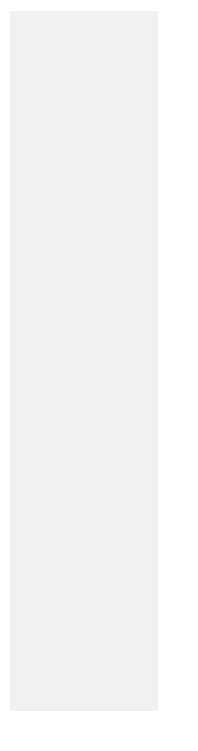

**3600 mm**

4 mm						
	UNI LIGHT					
6 mm						
	UNI LIGHT	UNI DARK	GRANIT	METALIC		
9 mm						
	UNI LIGHT	UNI DARK	GRANIT	METALIC	NATUR	MARBLE
12 mm						
	UNI LIGHT	UNI DARK	GRANIT	METALIC	TERAZZO	NATUR
	MARBLE	LUMINACO	LUMINO	EASY SHAPING	KERROCK MF	MIDNIGHT BLACK
18 mm						
	UNI LIGHT	UNI DARK	GRANIT			

180

**760 mm**

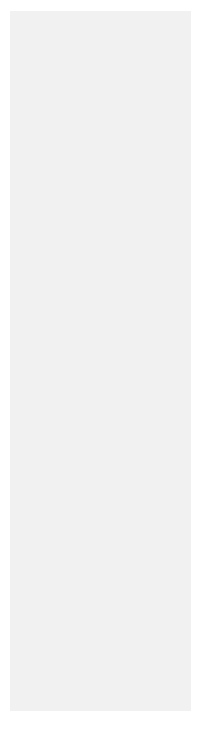

**3600 mm**

6 mm		
	UNI LIGHT	UNI DARK
12 mm		
	UNI LIGHT	UNI DARK

**930 mm**

Sheets of different dimensions are not of the same batch, so there may be a deviation in shade.  
 Platten mit unterschiedlichen Abmessungen sind nicht Teil der gleichen Charge, daher kann es zu Abweichungen im Farbton kommen.  
 Les panneaux de dimensions différentes n'étant pas du même lot, il peut donc subsister un écart de nuance.

# STANDARD SHEET DIMENSIONS. STANDARD-PLATTENABMESSUNGEN. DIMENSIONS STANDARD DES PANNEAUX.

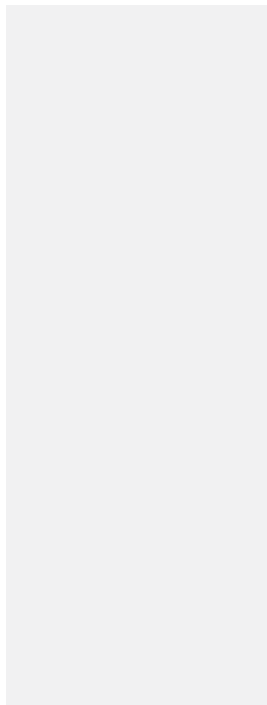



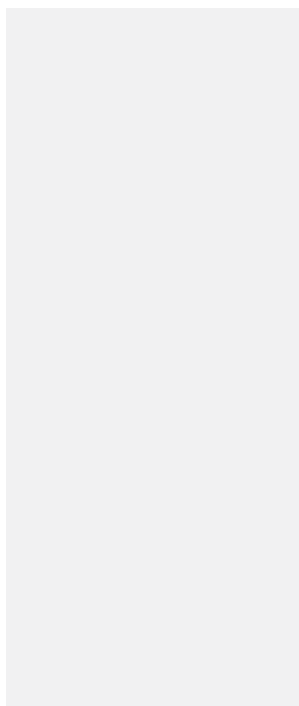















1350 mm



1520 mm

3600 mm

3600 mm

4 mm						
	UNI LIGHT					
<hr/>						
6 mm						
	UNI LIGHT	UNI DARK	GRANIT	METALIC		
<hr/>						
9 mm						
	UNI LIGHT	UNI DARK	GRANIT	METALIC	NATUR	
<hr/>						
12 mm						
	UNI LIGHT	UNI DARK	GRANIT	METALIC	TERAZZO	NATUR
<hr/>						
						
	LUMINACO	LUMINO	EASY SHAPING			

12 mm	
	108

Sheets of different dimensions are not of the same batch, so there may be a deviation in shade.  
 Platten mit unterschiedlichen Abmessungen sind nicht Teil der gleichen Charge, daher kann es zu Abweichungen im Farbton kommen.  
 Les panneaux de dimensions différentes n'étant pas du même lot, il peut donc subsister un écart de nuance.



**Project: Mesec family house**  
Škofja Loka, Slovenia  
Architecture: Jure Miklavc  
Manufacture: Janez Benedičič

# TECHNICAL DATA. TECHNISCHE DATEN. DONNÉES TECHNIQUES.

PROPERTY. EIGENSCHAFT. PROPRIÉTÉ.	VALUE. WERT. VALEUR.	METHOD. METHODE. MÉTHODE.
<b>VOLUME MASS</b> DICHTE VOLUME	1680-1750 kg/m <sup>3</sup>	SIST EN ISO 1183-1 Method A SIST EN ISO 1183-1 Methode A SIST EN ISO 1183-1 Méthode A
<b>FLEXURAL MODULUS</b> KRÜMMUNGSMODUL MODULE DE FLEXION	8600-9200 Mpa	SIST EN ISO 178
<b>FLEXURAL STRENGTH</b> KRÜMMUNGSHÄRTE RÉSISTANCE À LA FLEXION	49-80 Mpa	SIST EN ISO 178
<b>TENSILE STRENGTH</b> SPANNUNGSHÄRTE RÉSISTANCE À LA RUPTURE	36-50 Mpa	SIST EN ISO 527-2
<b>ELONGATION AT BREAK</b> DEHNUNG BEI BRUCH ALLONGEMENT À LA RUPTURE	0,50-0,90 %	SIST EN ISO 527-2
<b>TOUGHNESS</b> HÄRTE TENACITÉ	3,0-6,0 kJ/m <sup>2</sup>	SIST EN ISO 179-1
<b>HARDNESS (Barcol)</b> HÄRTE (nach Barcol) DURETÉ (selon Barcol)	58-64	SIST EN 59
<b>LINEAR EXPANSION COEFFICIENT</b> LINEARER DEHNUNGSKOEFIZIENT COEFFICIENT DE DILATATION LINÉAIRE	3,3-4,2 x 10 <sup>-5</sup> K <sup>-1</sup>	α (-20 °C - +50 °C)
<b>ABSORPTION (after 24 hours)</b> WASSERABSORPTION (nach 24 Stunden) ABSORPTION D'EAU (après 24 heures)	0,03-0,05 %	SIST EN ISO 62 Method 1 SIST EN ISO 62 Methode 1 SIST EN ISO 62 Méthode 1
<b>RESISTANCE TO WATER STEAM (1 hour)</b> BESTÄNDIGKEIT GEGEN WASSERDAMPFEINWIRKUNGEN (1 Stunde) RÉSISTANCE À LA VAPEUR D'EAU (1 heure)	Rating 5 – No visible changes Bewertung 5 – Keine sichtbare Veränderung Note 5 – Pas de changement visible	SIST EN 438-2
<b>RESISTANCE TO THE EFFECTS OF HOT COOKWARE</b> WIDERSTAND GEGEN DIE AUSWIRKUNGEN VON HEISSEM KOCHGESCHIRR RÉSISTANCE AUX EFFETS DES USTENSILES DE CUISINE CHAUDS	Rating 5 – No visible changes Bewertung 5 – Keine sichtbare Veränderung Note 5 – Pas de changement visible	SIST EN 438-2
<b>RESISTANCE TO THE EFFECTS OF A BURNING CIGARETTE</b> WIDERSTAND GEGEN DIE AUSWIRKUNGEN BRENNENDER ZIGARETTEN LA RÉSISTANCE AUX EFFETS DE LA COMBUSTION DE CIGARETTES	Rating 4 – insignificant change in shine, only visible under certain angles Bewertung 4 – geringfügige Glanzänderung, nur unter bestimmten Winkel sichtbar Note 4 – changement minime de brillance, visible seulement sous un certain angle	SIST EN 438-2
<b>RESISTANCE TO ATMOSPHERIC AGENTS</b> BESTÄNDIGKEIT ATMOSPHERÄN EINFLÜSSE RÉSISTANCE AUX AGENTS CLIMATIQUES	No change Keine Änderung Aucun changement	2-year outdoor exposure 2 Jahre Außeneinflüssen ausgesetzt Exposé 2 ans à l'extérieur
<b>CLASSIFICATION OF MATERIAL RESPONSE TO FIRE</b> KLASSIFIKATION DER REAKTION DES MATERIALS AUF FEUER CLASSIFICATION EN RÉSISTANCE AU FEU	B- s1, d0	SIST EN 13501-1
<b>SURFACE RESISTIVITY</b> OBERFLÄCHENHÄRTE RÉSISTANCE DE SURFACE	2,0 x 10 <sup>11</sup> – 2,0 x 10 <sup>12</sup> Ω	DIN VDE 0303-3 IEC 93
<b>SPECIFIC VISCOSITY RESISTIVITY</b> SPEZIFISCHE HÄRTE DES DURCHBRUCHS RÉSISTANCE DE PASSAGE SPÉCIFIQUE	7,9 x 10 <sup>13</sup> – 1,2 x 10 <sup>14</sup> Ω cm	DIN VDE 0303-3 IEC 93
<b>RESISTANCE TO TRACKING CURRENTS</b> KRIECHSTROMFESTIGKEIT RÉSISTANCE RELATIVE AU CHEMINEMENT DU COURANT DE FUITE	CTI 600 M	DIN VDE 0303-1 IEC 112
<b>RELATIVE DIELECTRIC CONSTANT (Er)</b> RELATIVE DIELEKTRISCHE KONSTANTE (Er) CONSTANTE DIÉLECTRIQUE RELATIVE (Er)	4,5	DIN VDE 0303-4 IEC 250
<b>DIELECTRIC LOSS FACTOR tg at MHz</b> FAKTOR DER DIELEKTRISCHEN VERLUSTE tg bei MHz FACTEUR DE PERTES DIÉLECTRIQUES tg à MHz	2,8 x 10 <sup>-3</sup>	DIN VDE 0303-4 IEC 250
<b>CONTACT WITH FOOD</b> KONTAKT MIT LEBENSMITTELN CONTACT AVEC LES ALIMENTS	Compliant with / Angemessen / Correspondante	Commission Regulation (EC) No 10/2011 (as amended until 2018) and Regulation (EC) No 1935/2004 of the European Parliament and of the Council. Verordnung (EG) Nr. 10/2011 der Kommission (in der bis 2018 geltenden Fassung) und Verordnung (EG) Nr. 1935/2004 des Europäischen Parlaments und des Rates. Règlement (CE) n° 10/2011 de la Commission (tel que modifié jusqu'en 2018) et règlement (CE) n° 1935/2004 du Parlement européen et du Conseil.



**Project: Magyar Pénzmúzeum és  
látogatóközpont**

Hungary

Architecture: Narmer Építészeti Stúdió

Photography: Alexandra Szűcs

Photography

Installation: Nezozen KFT



# CERTIFICATES. ZERTIFIKATE. CERTIFICATS.

Burning behaviour / Brandverhalten / Réaction au feu



Equipment of vehicles / Fahrzeugausrüstung / Équipement des véhicules



HOS emission / VOC-Emissionen / Émissions de COV



MED - Equipment of ships / MED – Schiffsausrüstung / MED – Équipement des navires



Equipment of rail vehicles / Zugausrüstung / Équipement des trains



EN 45545-2

ISO 9001, ISO 14001



Antibacterial effectiveness / Antibakterielle Wirksamkeit / Efficacité antibactérienne



Food contact – National Laboratory of Health, Environment and Food / Lebensmittelkontakt – Nationales Labor für Gesundheit, Umwelt und Nahrung / Contact avec les aliments – Laboratoire national pour la santé, l'environnement et l'alimentation



Facade and wall claddings – Slovenian National Building and Civil Engineering Institute / Fassaden und Wandverkleidungen – Slovensches Bauingenieurinstitut / Façades et revêtements muraux – Institut slovène de génie civil



Environmental Product Declaration – EPD / Umwelt-Produktdeklaration – EPD / Déclaration environnementale de produit – EPD



ISO 19712



LEED



REACH statement / REACH-Erklärung / Déclaration REACH



ID. 465884 2024/1

**kolpa**  
Est. 1978

KOLPA, d.o.o. Metlika  
Rosalnice 5,  
SI 8330 Slovenija  
Email: [info@kolpa.si](mailto:info@kolpa.si)  
Tel.: + 386 7 36 92 100

kerrock  
by KOLPA



kerrock.eu  
kerrock.de  
kerrock.lu



